

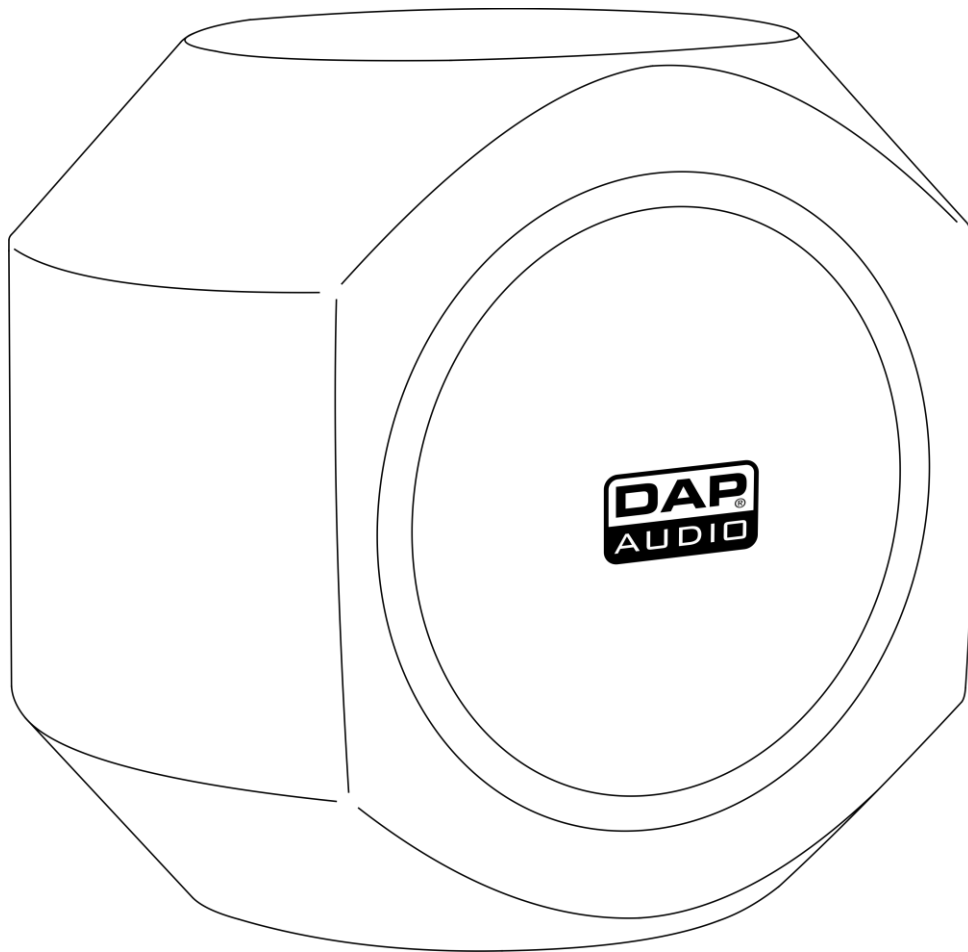

# MANUAL



**ENGLISH**

**Studio Eyeball**

**V1**

**Ordercode: D1397**

## Table of contents

---

<b>Warning</b> .....	2
Safety Instructions.....	2
Operating Determinations.....	2
Connection with the mains .....	3
Return Procedure .....	3
Claims .....	3
<b>Description of the device</b> .....	4
Overview.....	4
<b>Installation</b> .....	4
<b>Set Up and Operation</b> .....	5
Mounting of the Studio Eyeball .....	5
<b>Maintenance</b> .....	6
<b>Troubleshooting</b> .....	6
<b>Product Specifications</b> .....	6

## Warning



**For your own safety, please read this user manual carefully  
before your initial start-up!**



### Unpacking Instructions

Immediately upon receiving this product, carefully unpack the carton and check the contents to ensure that all parts are present, and have been received in good condition. Notify the dealer immediately and retain packing material for inspection if any parts appear damaged from shipping or the carton itself shows signs of mishandling. Save the carton and all packing materials. In the event that a device must be returned to the factory, it is important that the device is returned in the original factory box and packing.

### Your shipment includes:

- DAP Audio Studio Eyeball
- User manual

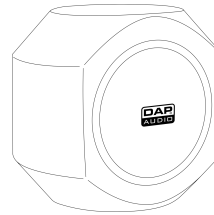

### Safety Instructions

Every person involved with the installation, operation and maintenance of this system has to:

- be qualified
- follow the instructions of this manual

Before the initial start-up, please make sure that there is no damage caused by transportation. Should there be any, consult your dealer and do not use the system.

To maintain perfect condition and to ensure a safe operation, it is absolutely necessary for the user to follow the safety instructions and warning notes written in this manual.

Please consider that damages caused by manual modifications to the system are not subject to warranty.

This system contains no user-serviceable parts. Refer servicing to qualified technicians only.

### IMPORTANT:

The manufacturer will not accept liability for any resulting damages caused by the non-observance of this manual or any unauthorized modification to the device.

- Never remove warning or informative labels from the unit.
- Do not modify the device.
- Only use device indoors, avoid contact with water or other liquids.
- Avoid flames and do not put close to flammable liquids or gases.
- If your Dap Audio device fails to work properly, discontinue use immediately. Pack the unit securely (preferably in the original packing material), and return it to your Dap Audio dealer for service.
- Repairs, servicing and electric connection must be carried out by a qualified technician.
- WARRANTY: Till one year after date of purchase.

### Operating Determinations

This system is not designed for permanent operation. Consistent operation breaks will ensure that the system will serve you for a long time without defects.

If this system is operated in any other way than the one described in this manual, the product may suffer damages and the warranty becomes void.

Any other operation may lead to dangers like short-circuit, burns, electric shock, etc.

*You endanger your own safety and the safety of others!*

*Improper installation can cause serious damage to people and property !*

## Connection with the mains

Connect the device to the mains with the power-plug.

Always pay attention, that the right color cable is connected to the right place.

International	EU Cable	UK Cable	US Cable	Pin
L	BROWN	RED	YELLOW/COPPER	PHASE
N	BLUE	BLACK	SILVER	NEUTRAL
	YELLOW/GREEN	GREEN	GREEN	PROTECTIVE GROUND

*Make sure that the device is always connected properly to the earth!*

*Improper installation can cause serious damage to people and property!*

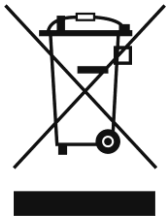

### Return Procedure



Returned merchandise must be sent prepaid and in the original packing, call tags will not be issued. Package must be clearly labeled with a Return Authorization Number (RMA number). Products returned without an RMA number will be refused. Highlite will not accept the returned goods or any responsibility. Call Highlite 0031-455667723 or mail [aftersales@highlite.nl](mailto:aftersales@highlite.nl) and request an RMA prior to shipping the fixture. Be prepared to provide the model number, serial number and a brief description of the cause for the return. Be sure to properly pack fixture, any shipping damage resulting from inadequate packaging is the customer's responsibility. Highlite reserves the right to use its own discretion to repair or replace product(s). As a suggestion, proper UPS packing or double-boxing is always a safe method to use.

**Note: If you are given an RMA number, please include the following information on a piece of paper inside the box:**

- 01) Your name
- 02) Your address
- 03) Your phone number
- 04) A brief description of the symptoms

### Claims

The client has the obligation to check the delivered goods immediately upon delivery for any short-comings and/or visible defects, or perform this check after our announcement that the goods are at their disposal. Damage incurred in shipping is the responsibility of the shipper; therefore the damage must be reported to the carrier upon receipt of merchandise.

It is the customer's responsibility to notify and submit claims with the shipper in the event that a fixture is damaged due to shipping. Transportation damage has to be reported to us within one day after receipt of the delivery.

Any return shipment has to be made post-paid at all times. Return shipments must be accompanied with a letter defining the reason for return shipment. Non-prepaid return shipments will be refused, unless otherwise agreed in writing.

Complaints against us must be made known in writing or by fax within 10 working days after receipt of the invoice. After this period complaints will not be handled anymore.

Complaints will only then be considered if the client has so far complied with all parts of the agreement, regardless of the agreement of which the obligation is resulting.

### Description of the device

---

The DAP Audio Studio Eyeball is a foam reflection filter with an integrated premium pop filter, which can be mounted onto a large diaphragm studio microphone. The Studio Eyeball is suitable for most studio microphones.

#### Features

- Microphone opening:  $\varnothing$  43 mm
- Material: Foam & plastic
- Dimensions: 200 x 165 x 182 mm (LxWxH)
- Weight: 0,14 kg

#### Overview

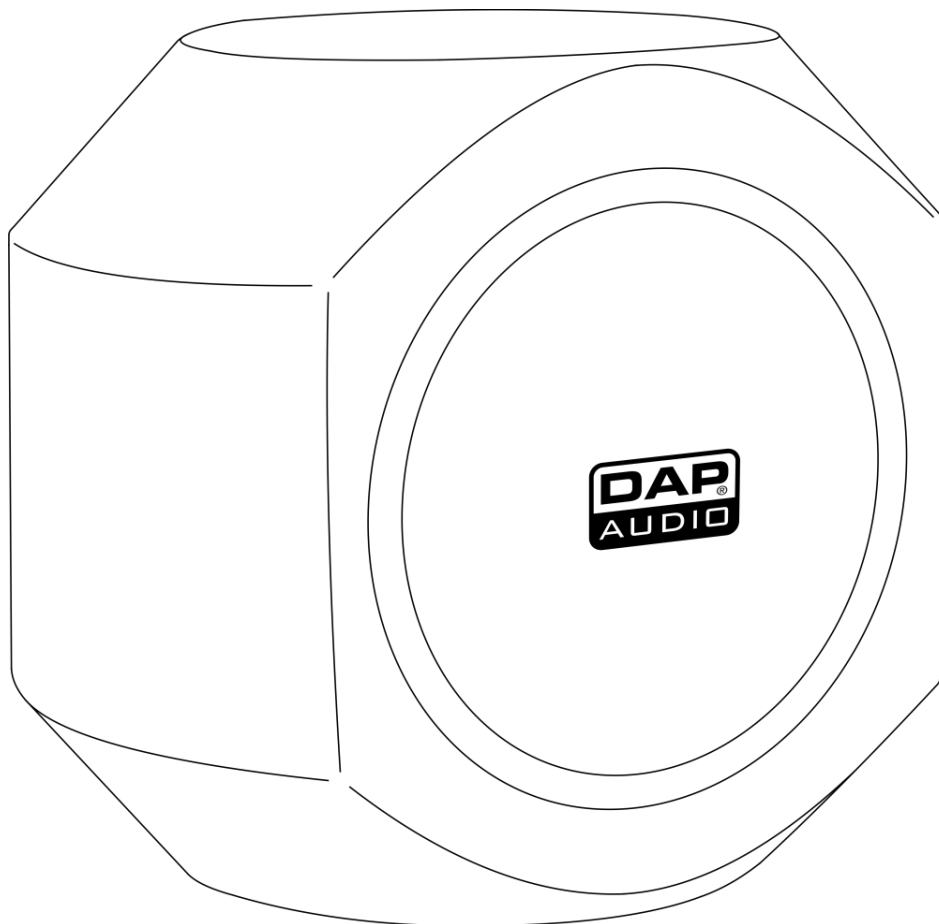

Fig. 01

### Installation

---

Remove all packing materials from the Studio Eyeball. Check if all foam and plastic padding is removed.  
**Damages caused by non-observance are not subject to warranty.**

## Set Up and Operation

Follow the directions below, as they pertain to your preferred operation mode.

**Damages caused by non-observance are not subject to warranty.**

### Mounting of the Studio Eyeball

- 01) Mount the Studio Eyeball onto a studio microphone.
- 02) If you need to install a small microphone, you can use the included adapter to create more stability.

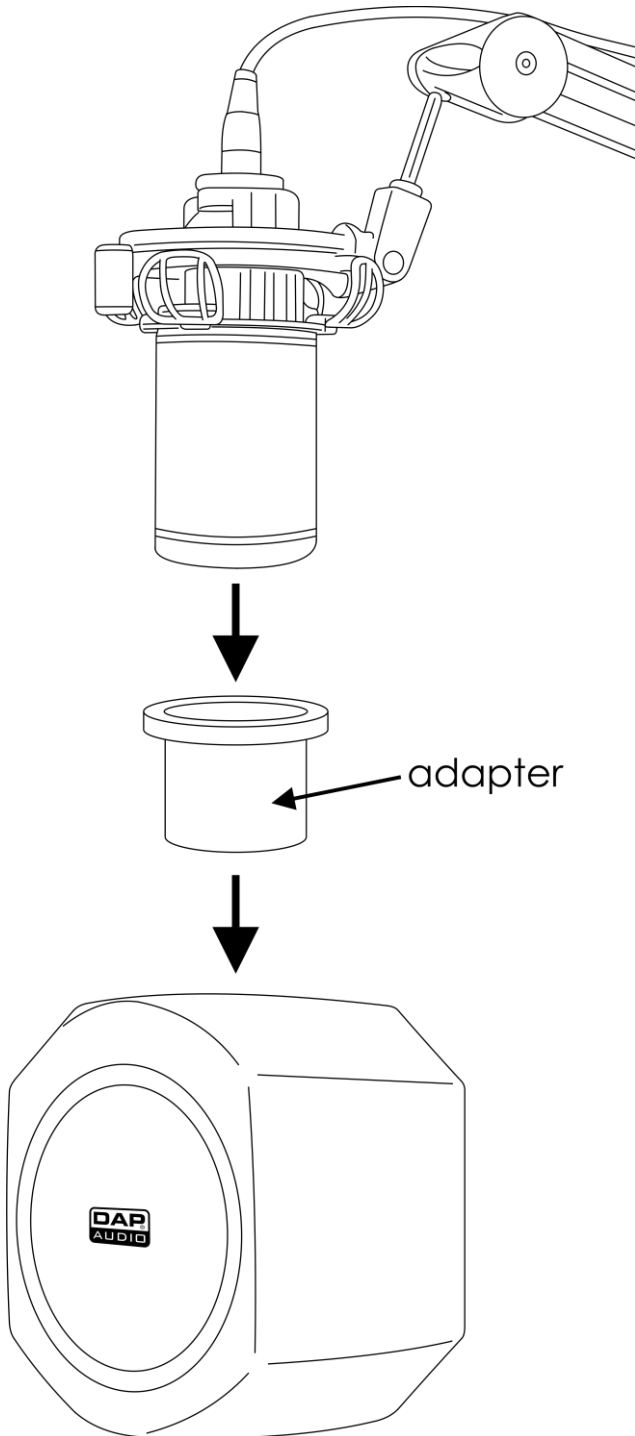

Fig. 02

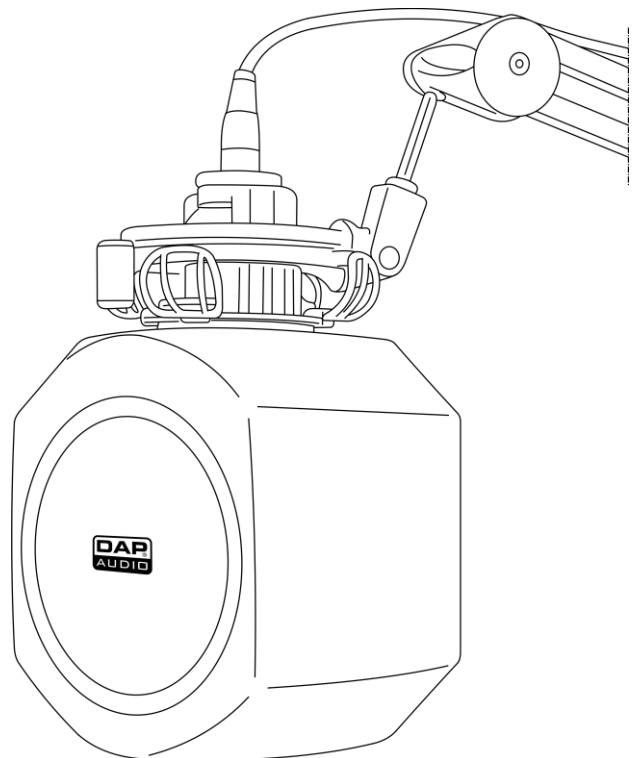

Fig. 03

## Maintenance

The DAP Audio Studio Eyeball requires almost no maintenance. However, you should keep the unit clean. Wipe with a damp cloth. Do not immerse in liquid. Do not use alcohol or solvents.

## Troubleshooting

DAP Audio Studio Eyeball

This troubleshooting guide is meant to help solve simple problems. Follow the advice below.

01) If the device does not function properly, return the device to your DAP Audio dealer.

## Product Specifications

Model:	DAP Audio Studio Eyeball
Material:	Foam & plastic
Dimensions:	200 x 165 x 182 mm (LxWxH)
Weight:	0,14 kg

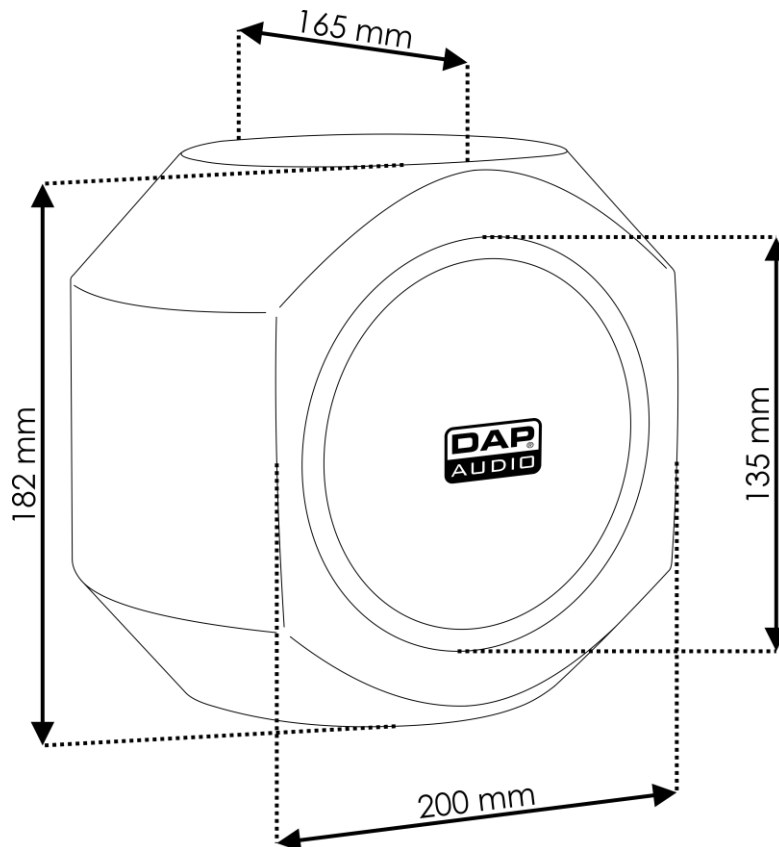

Design and product specifications are subject to change without prior notice.



Website: [www.Dap-audio.info](http://www.Dap-audio.info)  
Email: [service@highlife.nl](mailto:service@highlife.nl)



©2017 DAP Audio