

pocket  
operator™  
modular

モジュール

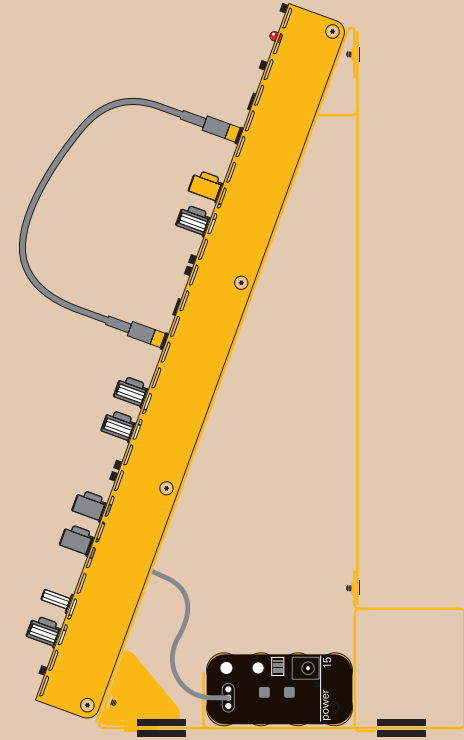
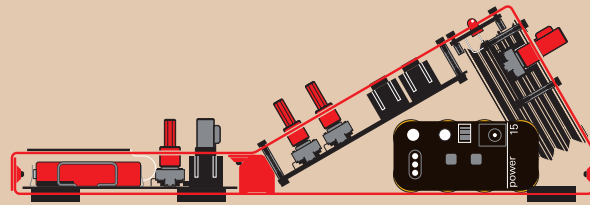
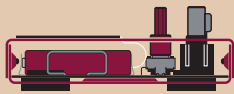

16

170

400

# symbols

learn the meaning of the symbols on the opposite page before you start building. for in-depth instructions read the online guide.

lerne die bedeutung der symbole auf der gegenüberliegenden seite bevor du mit dem zusammenbau beginnst. für weitere anweisungen lesen sie bitte den online-guide.

il est important d'apprendre le signification de ces symboles avant de commencer la construction. pour plus d'informations, veuillez lire de notre guide en ligne.

è importante imparare il significato di questi simboli prima di iniziare a costruire. per ulteriori istruzioni leggere la guida online.

各シンボルの意味について事前に別ページの記載を確認の上、組み立てを開始してください。

# bending

use a desk or similar as a support when you bend the sheet metal and its flanges. pay close attention to the direction of the bends before you bend as you only have one attempt before the support tabs lose their strength and you may rip the part. unfortunately, bent chassis cannot be returned.

erwenden sie einen schreibtisch oder ähnliches als unterstützung, wenn sie das blech und seine flansche biegen. achte genau auf die richtung der biegungen, bevor du dich biegst, da du nur einen versuch hast, bevor die stützlaschen ihre stärke verlieren und du sie reißen kannst...

utilisez un bureau ou un support similaire lorsque vous pliez la tôle et ses brides. portez une attention particulière à la direction des plis avant de vous pencher, car vous n'avez qu'une seule tentative avant que les pattes de soutien ne perdent de leur force et que vous ne puissiez les déchirer.

utilizza una scrivania o simile come supporto per piegare la lamiera e le sue flange. fai molta attenzione alla direzione delle curve prima di piegare, poiché hai solo un tentativo prima che le linguette di supporto perdano la loro forza e potresti strapparle.

ケースの金属シートおよびフランジ部を曲げる際は、作業機などを補助に使用してください。また、曲げる方向について事前に十分確認の上、作業するよう注意してください。曲げられるのは1回のみとなります。それ以上はタブ部分が緩み、強度を失い破損するおそれがあります。



main parts  
A–F



module  
1–16

CH PM

sheet metal  
chassi kit

pocket operator  
modular system



pay attention to  
the detail within  
the circle

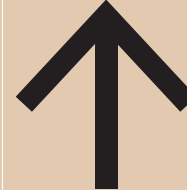

note the  
direction



build step  
1...2...3



press all the way  
down and make  
sure it's flat



sheet metal  
screw



module screw  
M2



torx T8



stand-off  
Ø 4 X 14  
Ø 4 X 5



trim knob



value knob

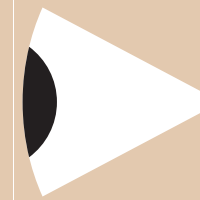

see page no.  
for detailed  
information



task completed



screwdriver  
torx T8

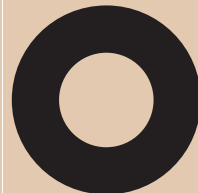

rubber foot



rubber foot for  
keyboard

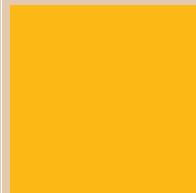

400 color

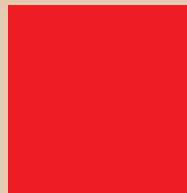

170 color

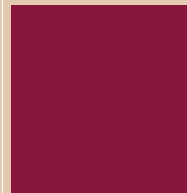

16 color



attention  
critical detail

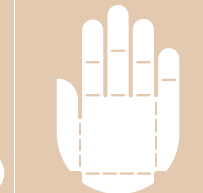

wise quotes

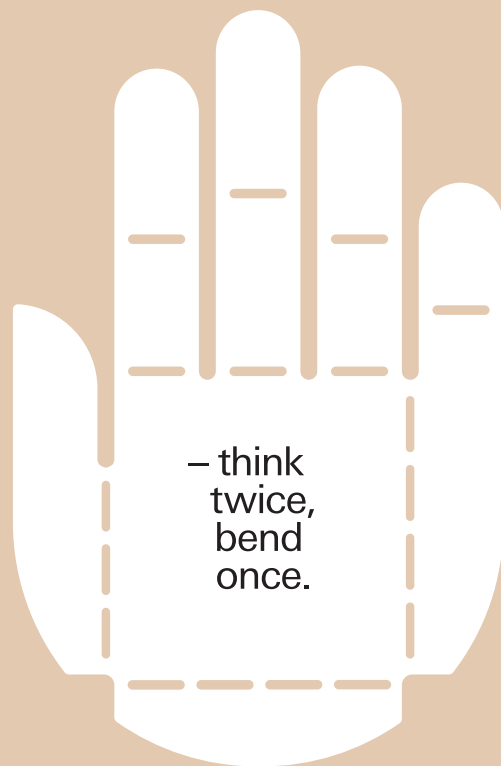



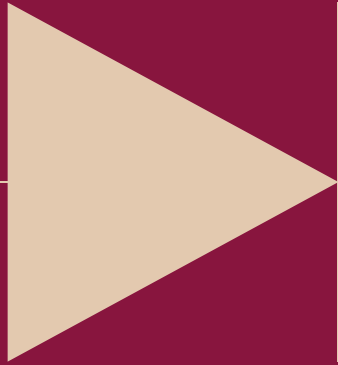

16

# let's build

for in-depth instructions visit  
[teenage.engineering/guides](https://teenage.engineering/guides)

ausführliche anweisungen  
findest du unter  
[teenage.engineering/guides](https://teenage.engineering/guides)

pour des instructions plus  
approfondies, visitez  
[teenage.engineering/guides](https://teenage.engineering/guides)

per istruzioni dettagliate,  
visitare il sito web  
[teenage.engineering/guides](https://teenage.engineering/guides)

詳しくは、マニュアルを読んでください。  
[teenage.engineering/guides](https://teenage.engineering/guides)

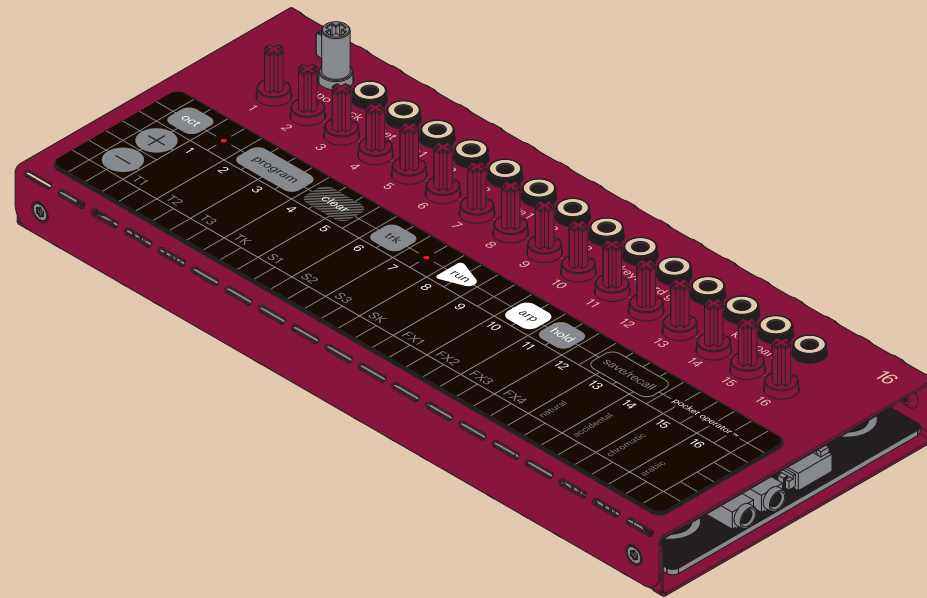

# parts

identify parts  
 teile identifizieren  
 identifier les pièces  
 identifica le parti  
 パーツの確認

**A**

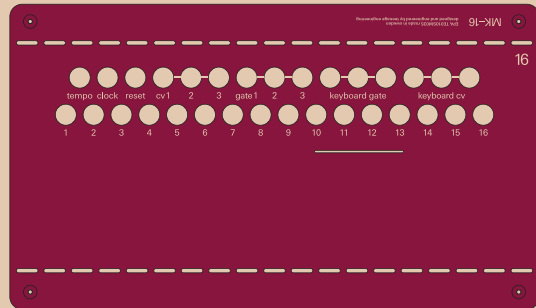

**C**

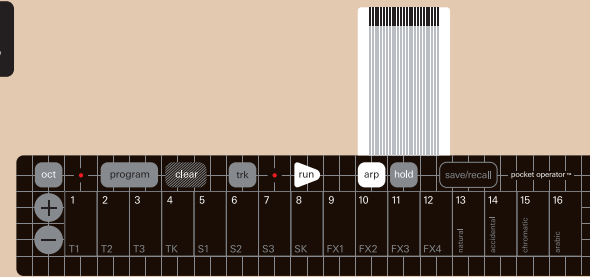

**B**

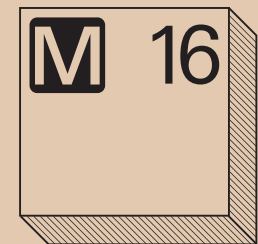
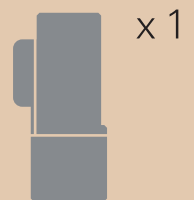
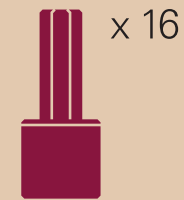
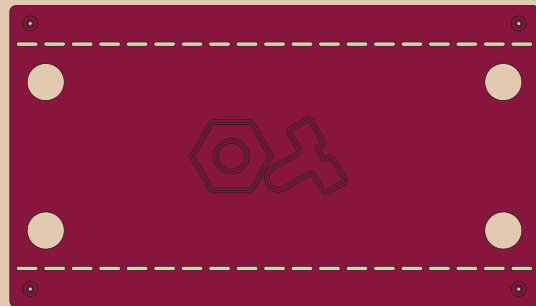

1

A

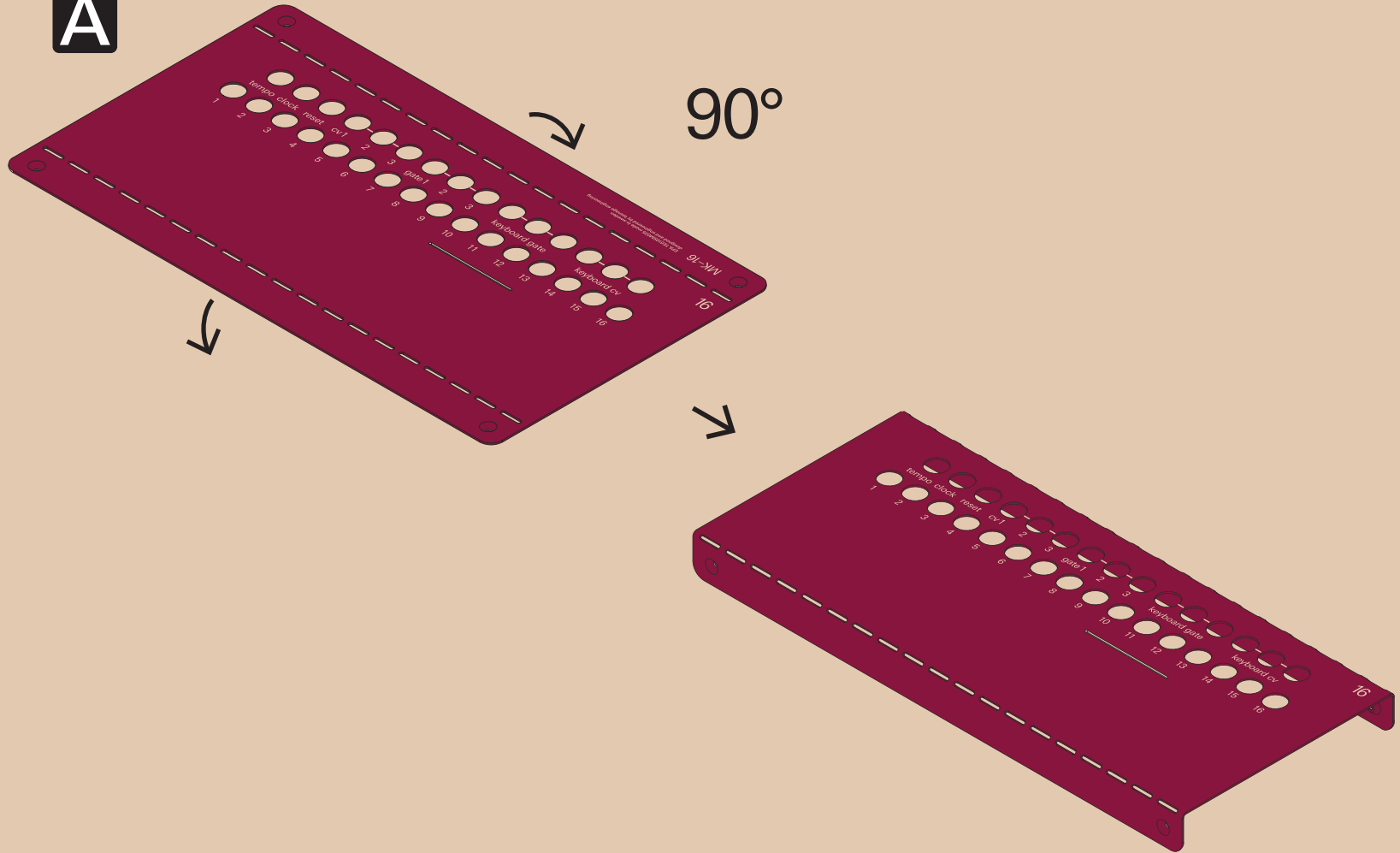

# 2

# C

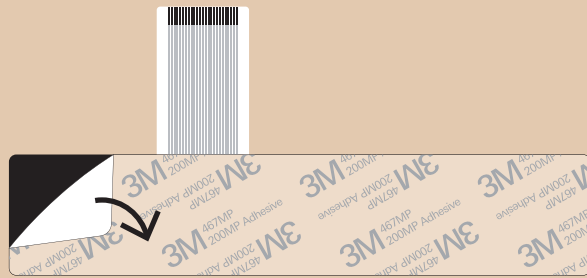
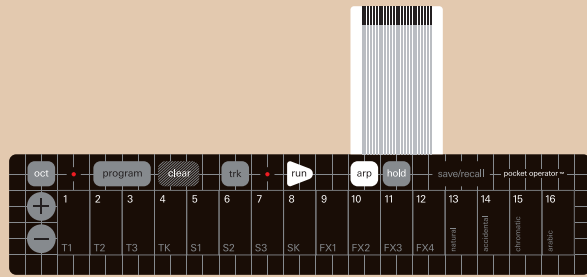

# 3

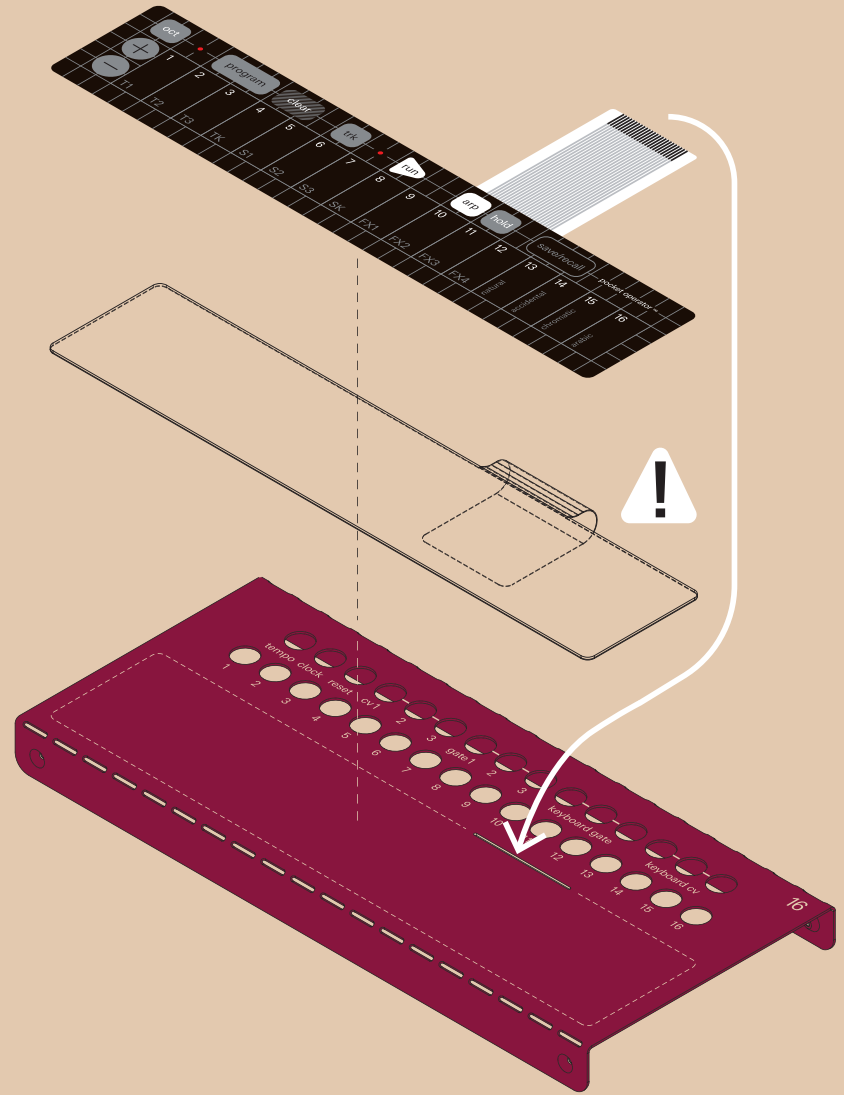

4

**B**

90°

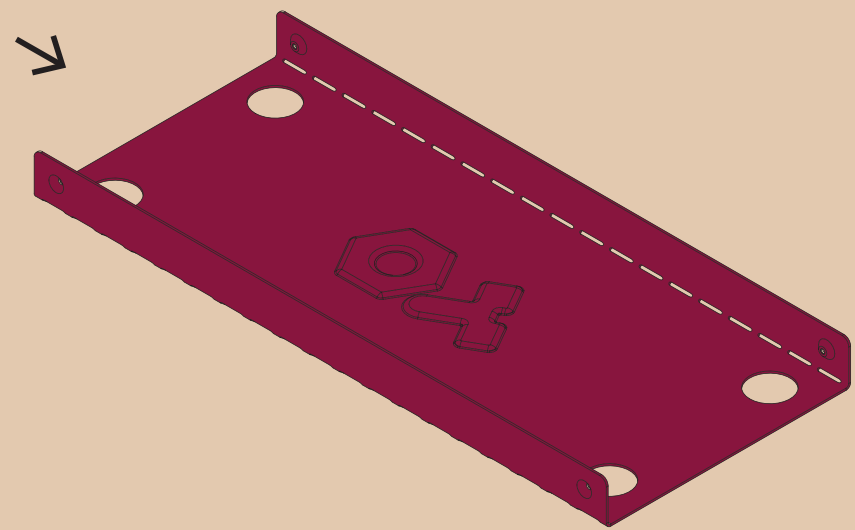
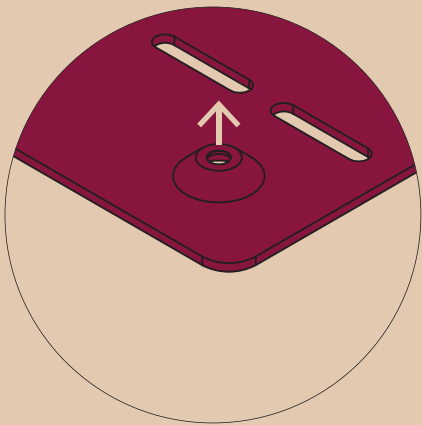
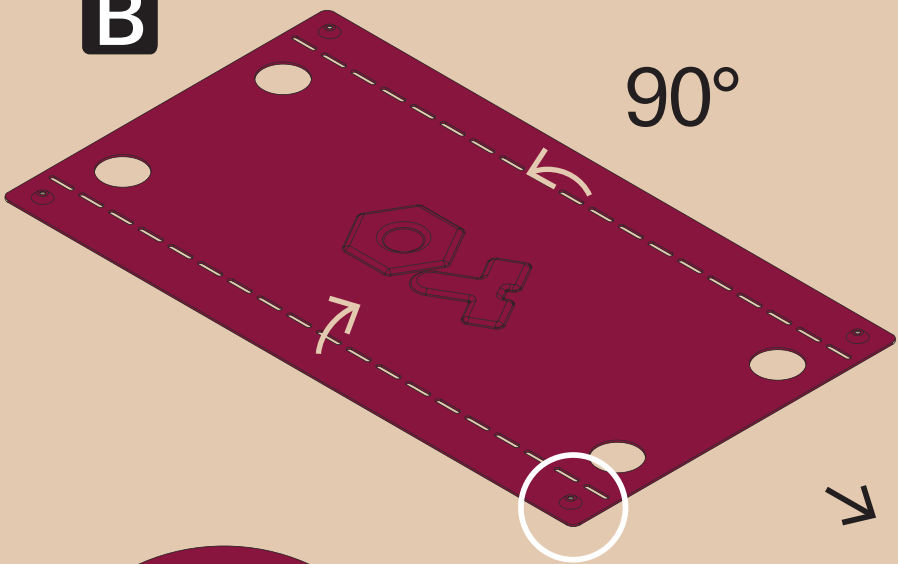

5

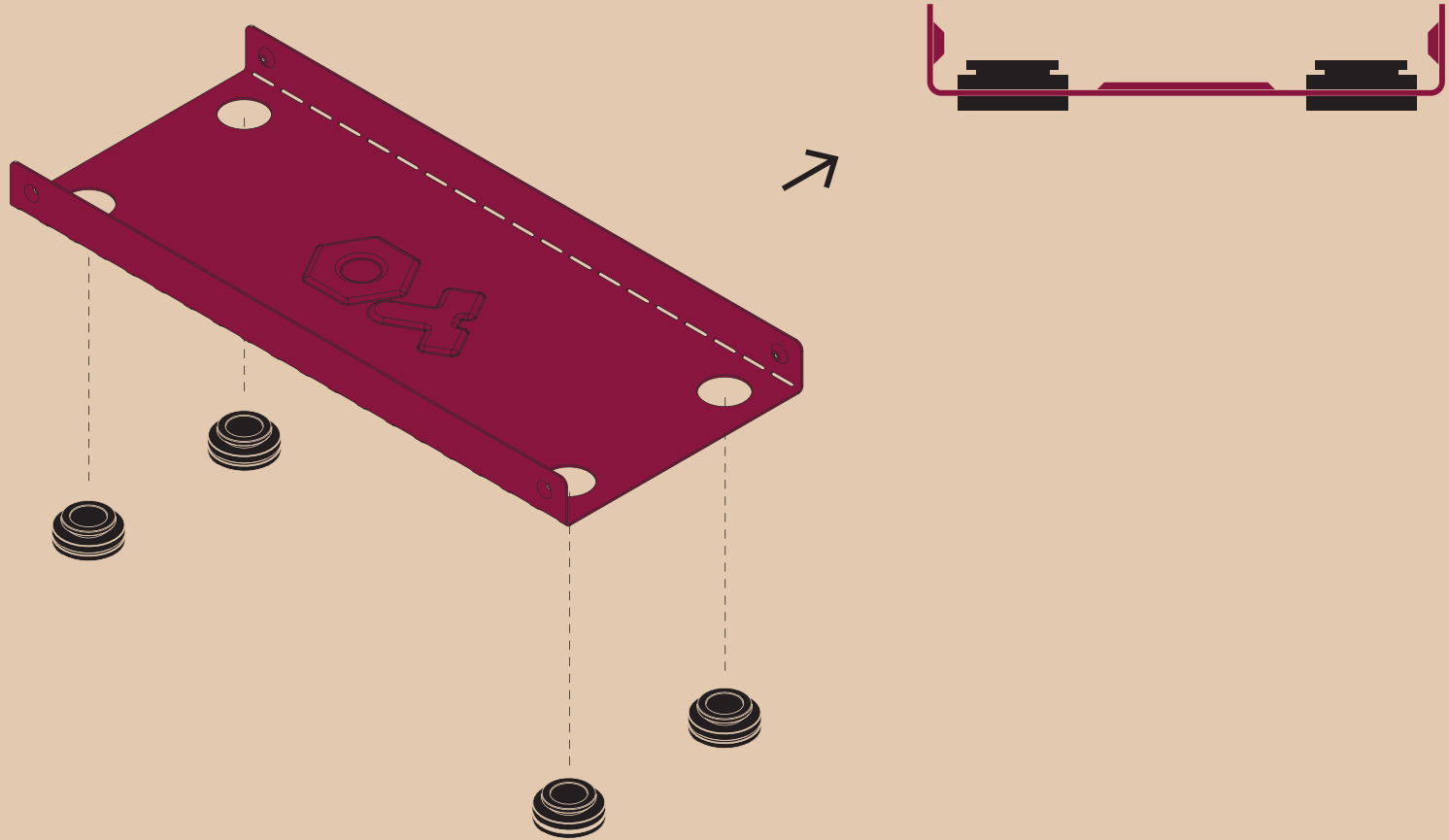

6

M16

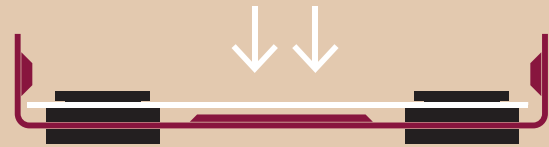
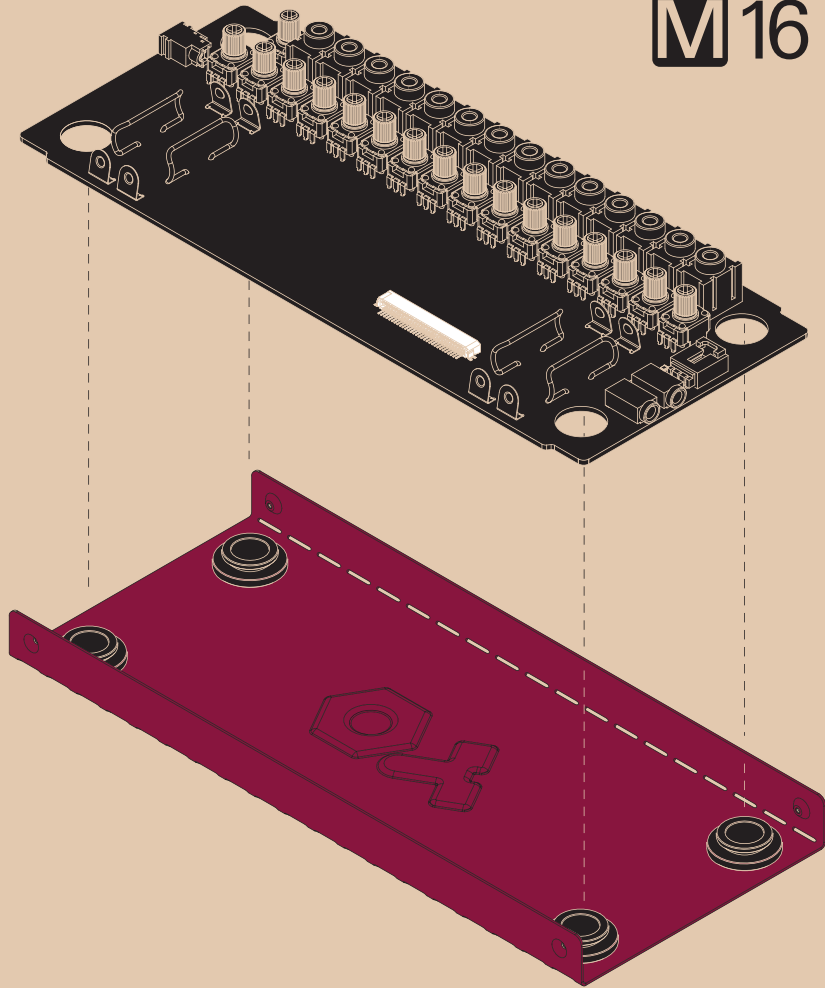



# 7

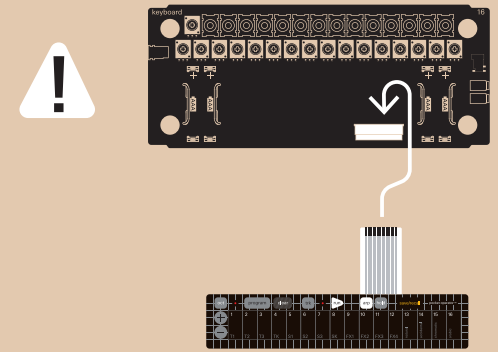
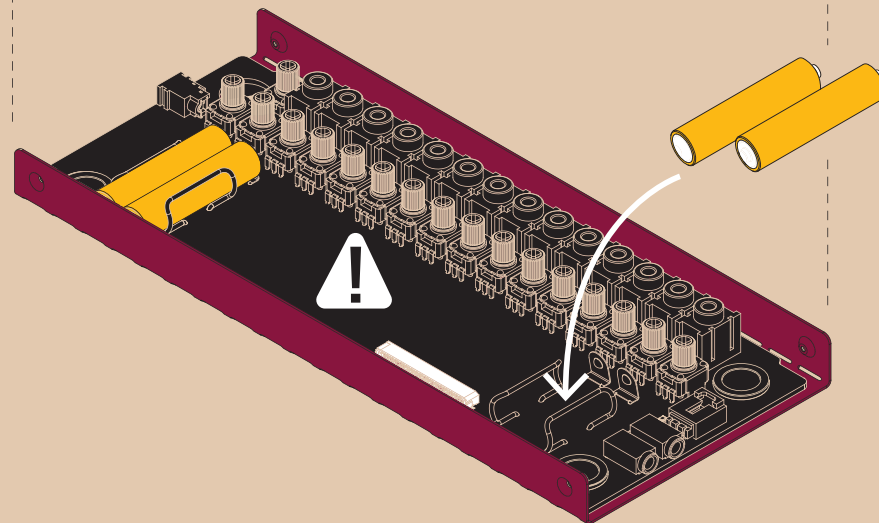
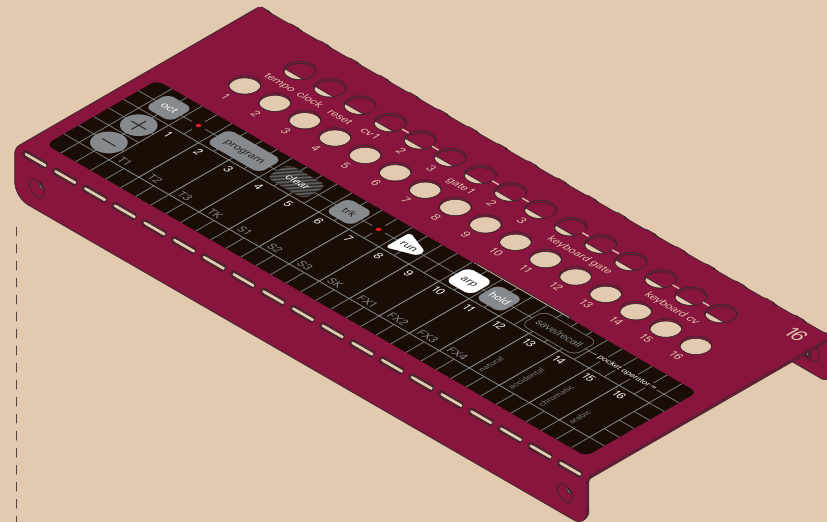

AAA x 4

# 8

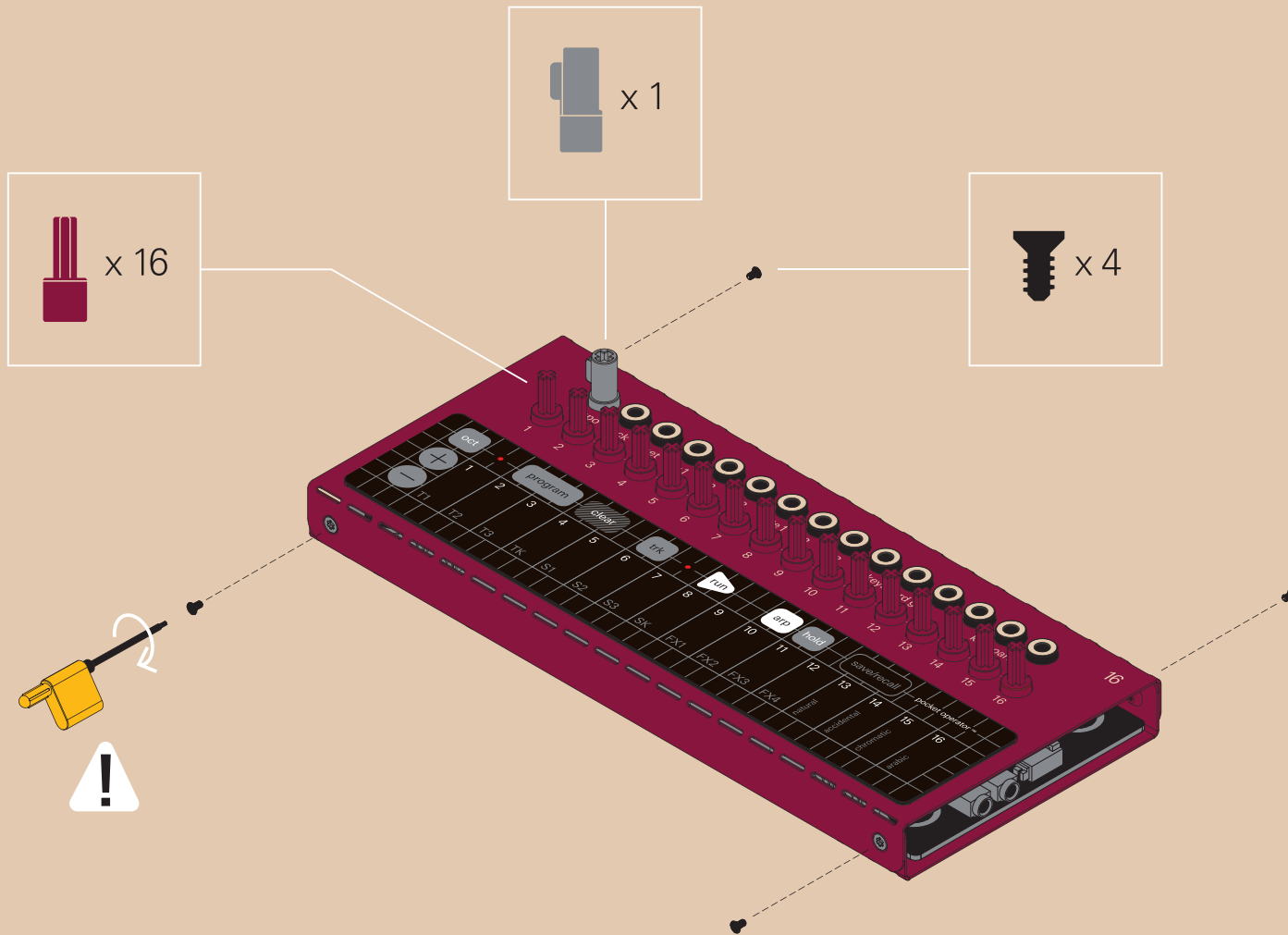

do not over tighten screws  
schrauben nicht zu fest anziehen  
ne pas trop serrer les vis  
non stringere troppo le viti  
ネジを締めすぎないようにご注意ください



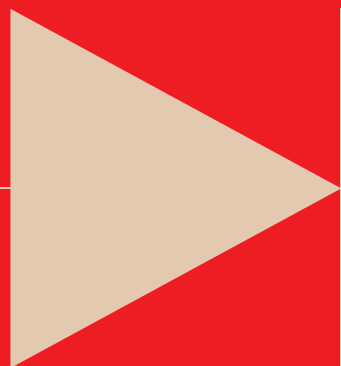

170

# let's build

for in-depth instructions visit  
[teenage.engineering/guides](http://teenage.engineering/guides)

ausführliche anweisungen  
findest du unter  
[teenage.engineering/guides](http://teenage.engineering/guides)

pour des instructions plus  
approfondies, visitez  
[teenage.engineering/guides](http://teenage.engineering/guides)

per istruzioni dettagliate,  
visitare il sito web  
[teenage.engineering/guides](http://teenage.engineering/guides)

詳しくは、マニュアルを読んでください。  
[teenage.engineering/guides](http://teenage.engineering/guides)

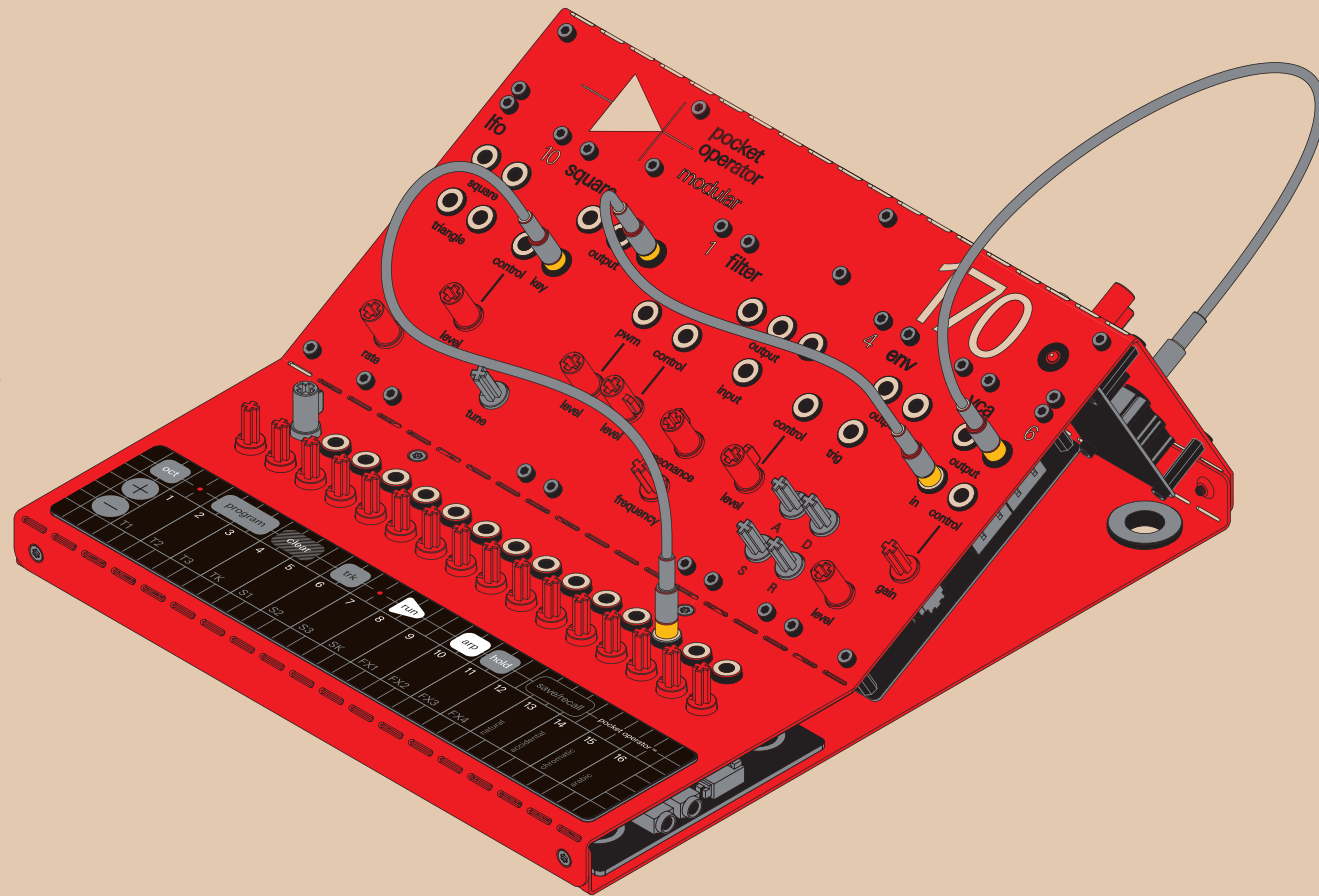

# parts

identify parts  
teile identifizieren  
identifier les pièces  
identifica le parti  
パーツの確認



**A**

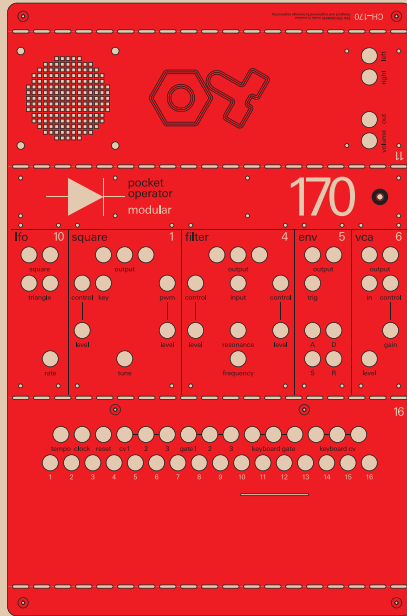

**B**

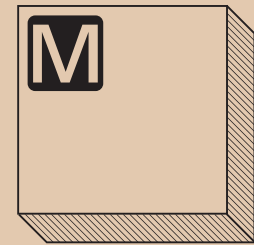
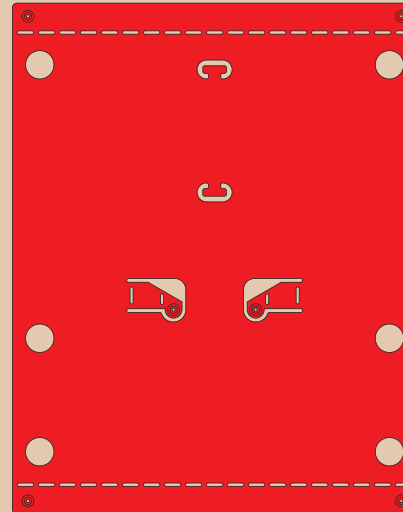

1, 4, 5, 6, 10,  
11, 14, 16

**M**



x 56



x 24



x 8



x 18



x 8



x 5



x 1

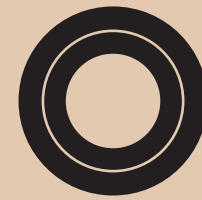

x 4



x 2

# 1

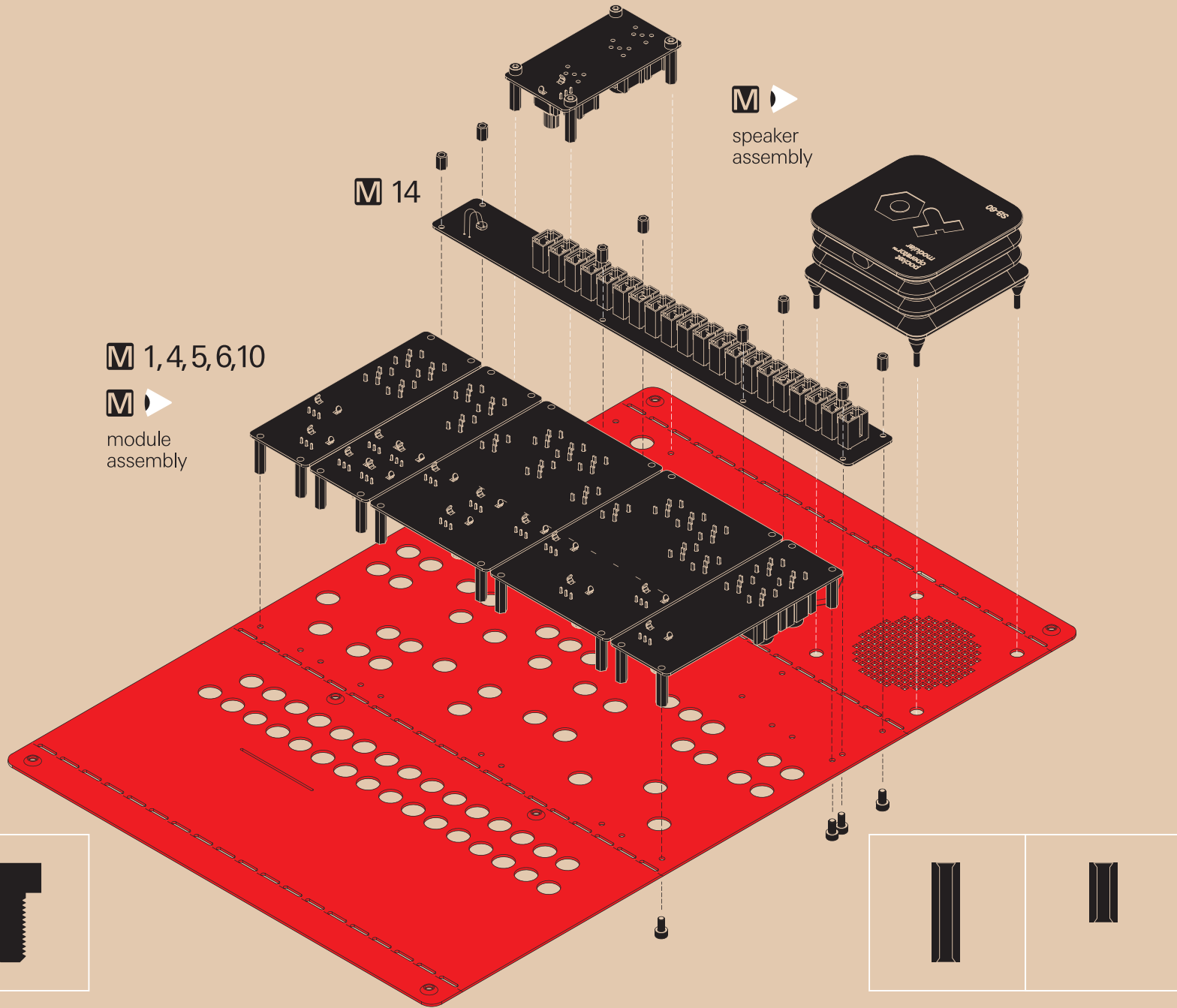

2

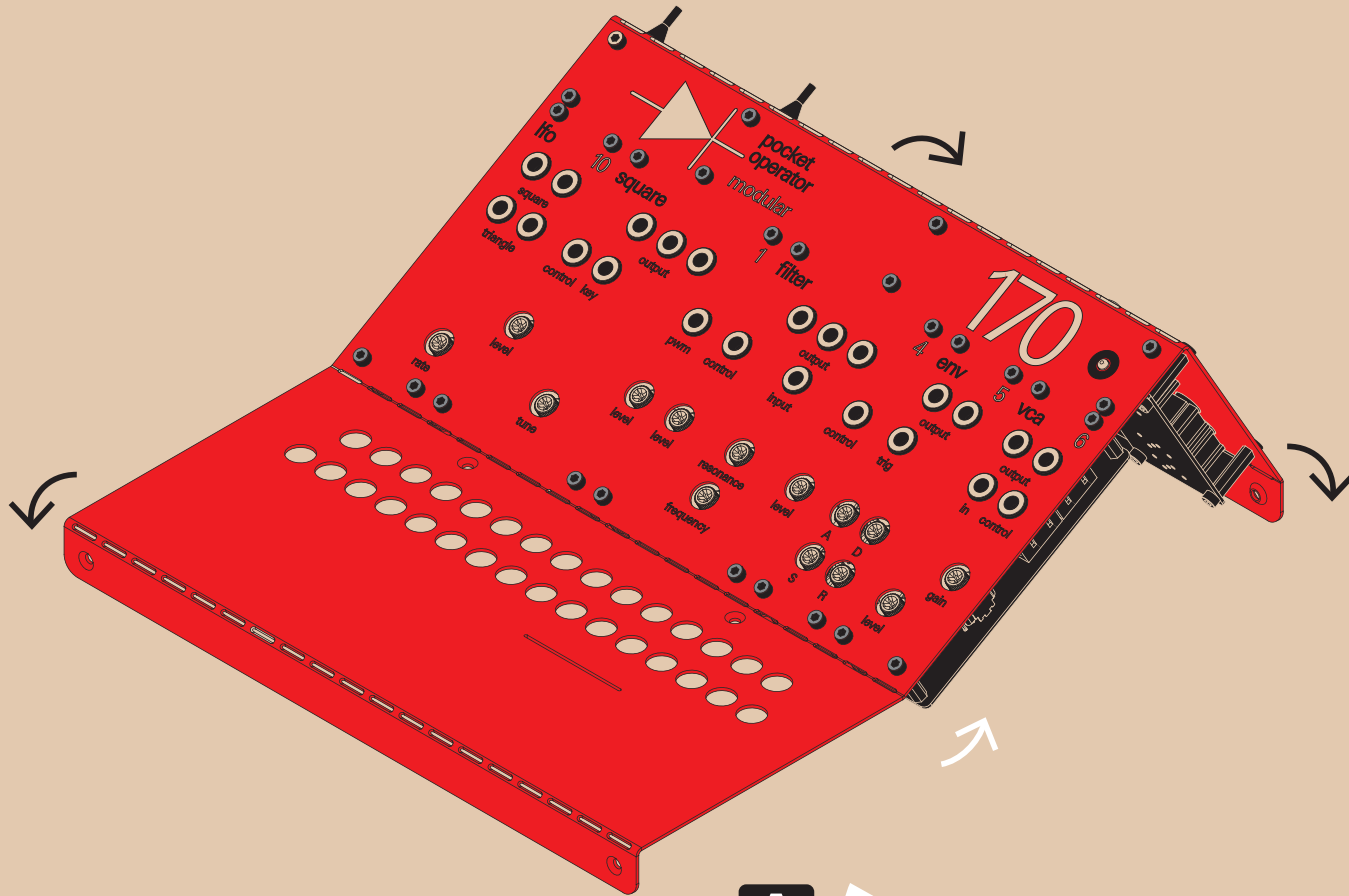

# 3

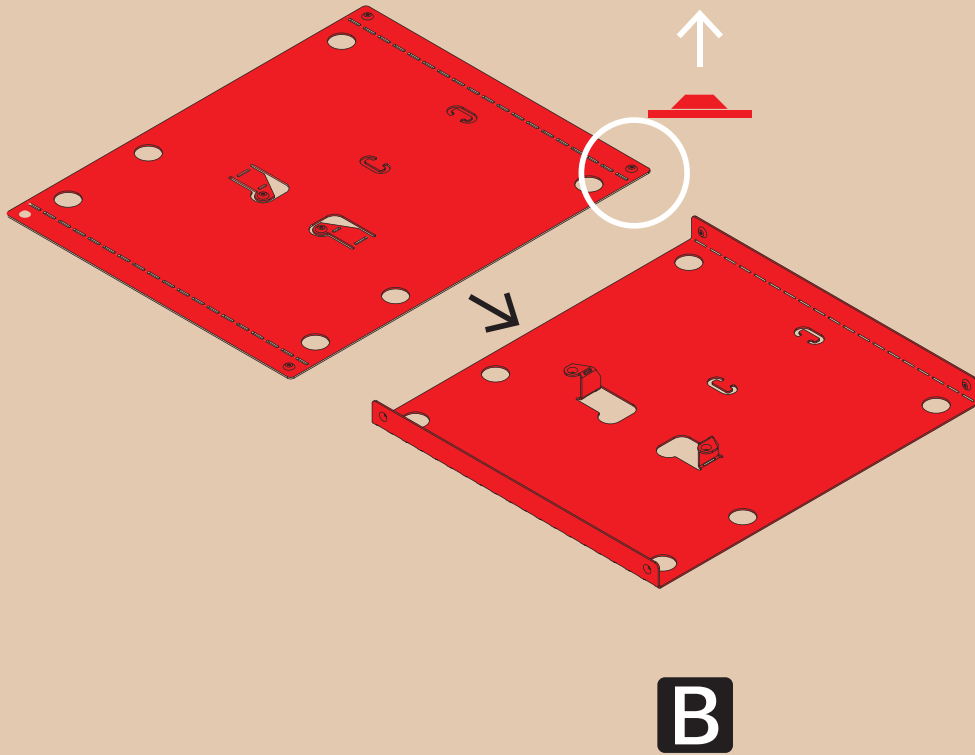

# 4

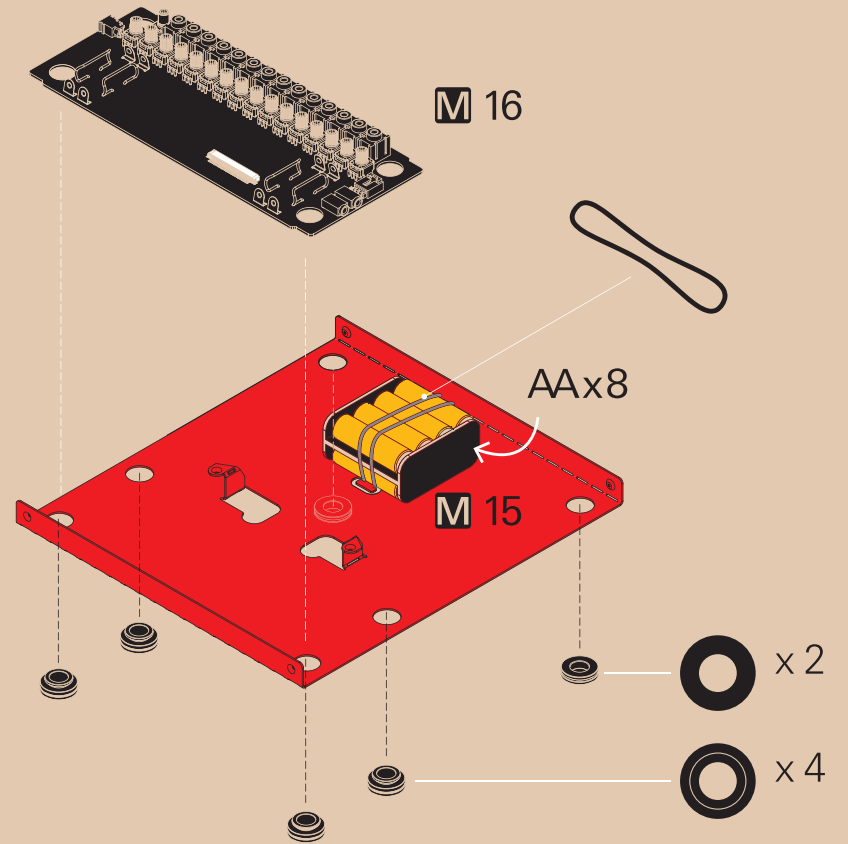



**A** 1:1



**B**



# 5

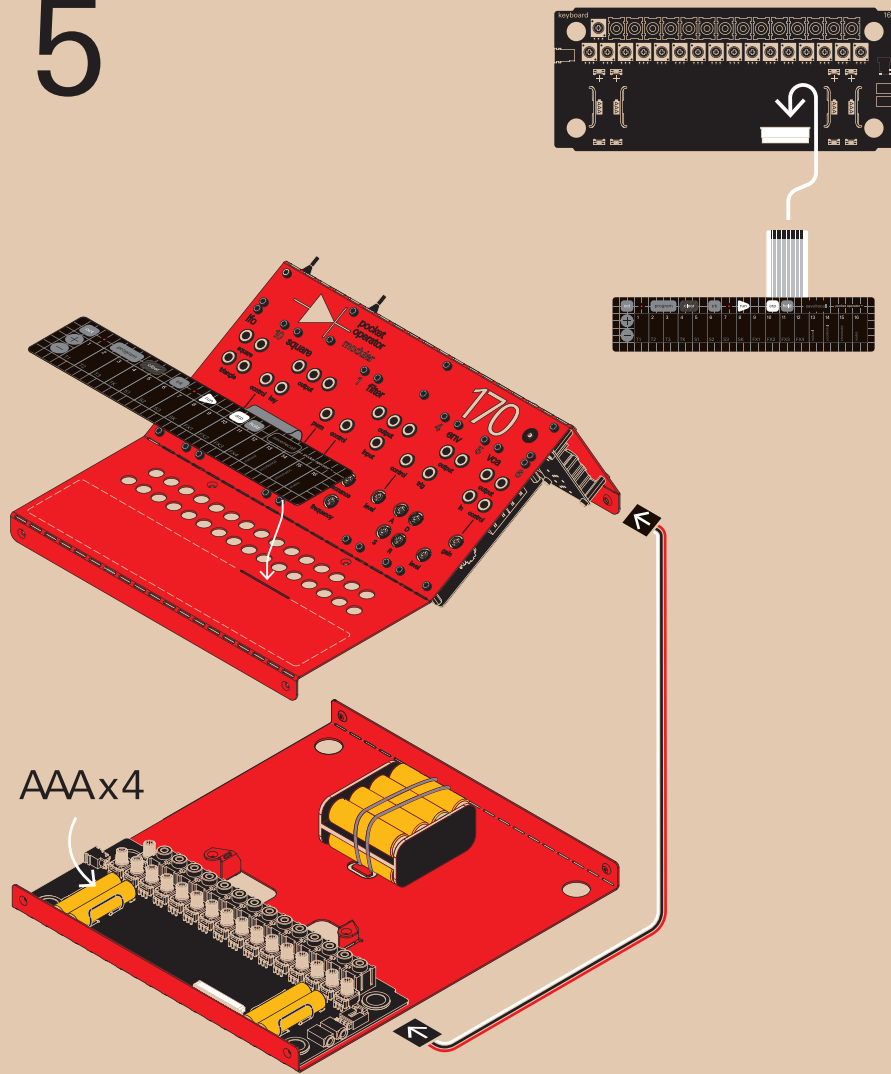

AAAx4

remove batteries if using a power adapter  
entferne die batterien, wenn ein netzteil verwendet wird  
retirez les piles si vous utilisez un adaptateur secteur  
rimuovere le batterie se si utilizza un alimentatore  
電源アダプタを使用している場合は電池を取り外します

# 6

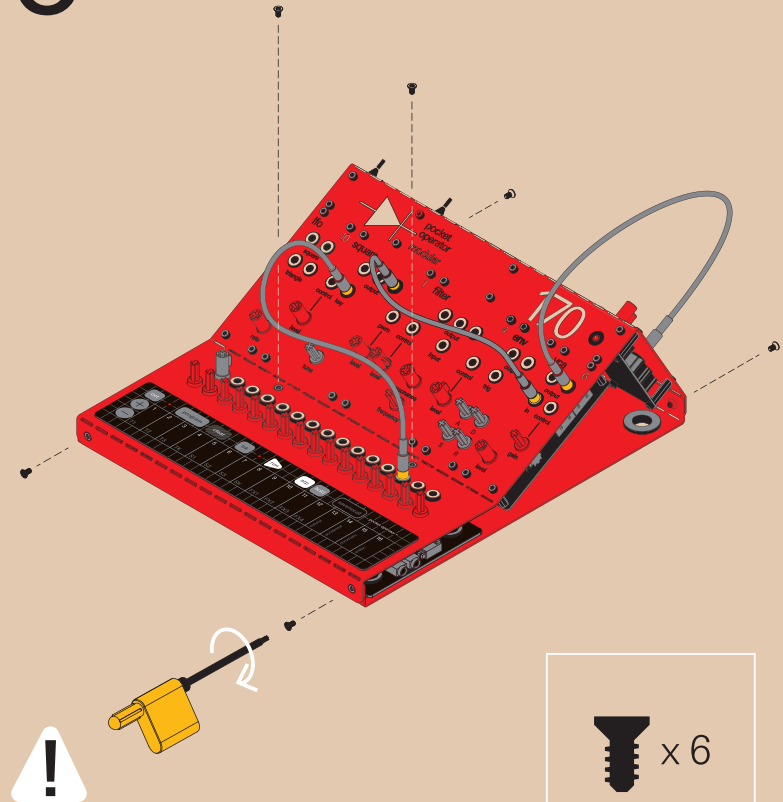

x 6

do not over tighten screws  
schrauben nicht zu fest anziehen  
ne pas trop serrer les vis  
non stringere troppo le viti  
ネジを締めすぎないようにご注意ください

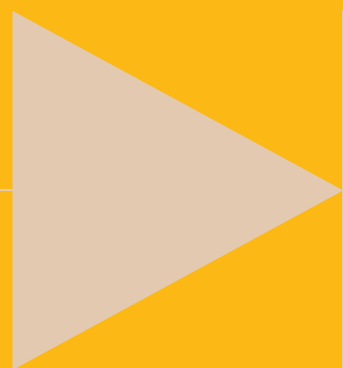

400

# let's build

for in-depth instructions visit  
[teenage.engineering/guides](http://teenage.engineering/guides)

ausführliche anweisungen  
findest du unter  
[teenage.engineering/guides](http://teenage.engineering/guides)

pour des instructions plus  
approfondies, visitez  
[teenage.engineering/guides](http://teenage.engineering/guides)

per istruzioni dettagliate,  
visitare il sito web  
[teenage.engineering/guides](http://teenage.engineering/guides)

詳しくは、マニュアルを読んでください。  
[teenage.engineering/guides](http://teenage.engineering/guides)

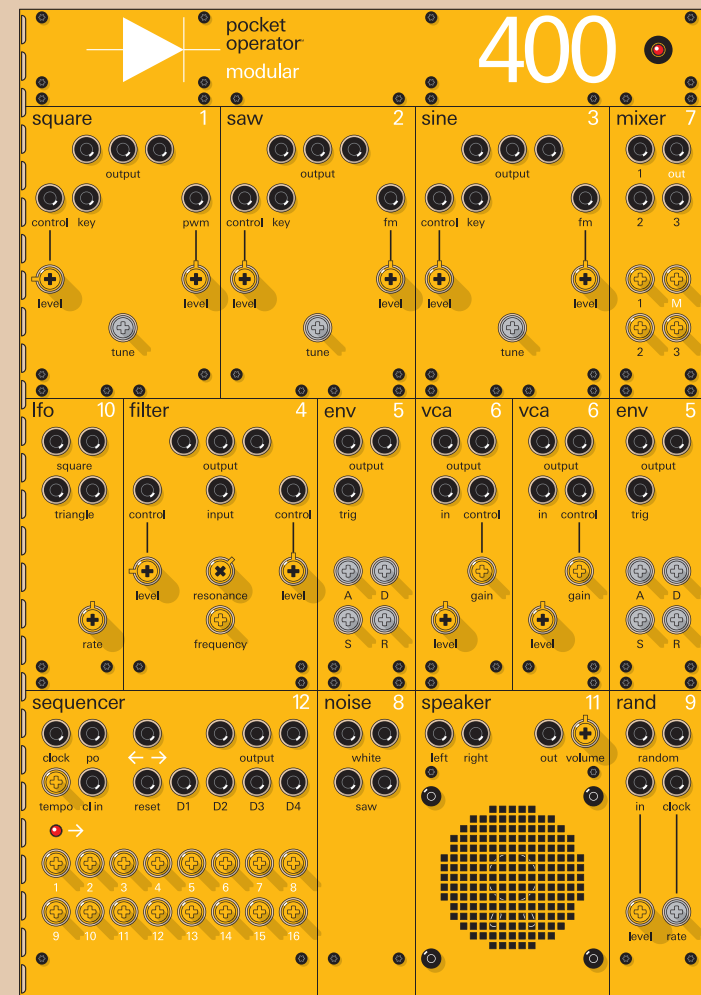
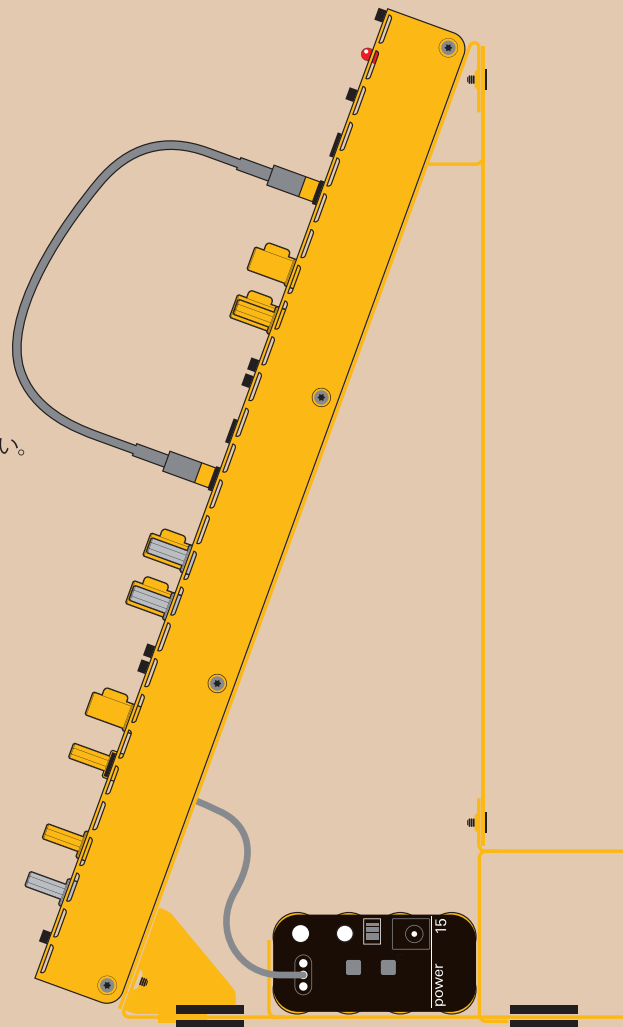

# parts

identify parts  
teile identifizieren  
identifier les pièces  
identifica le parti  
パーツの確認

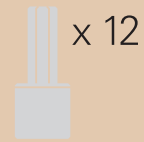

**A**

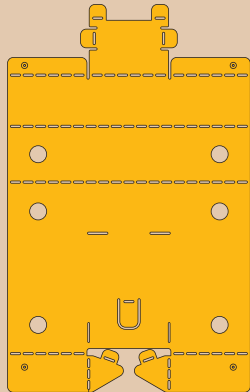

**B**

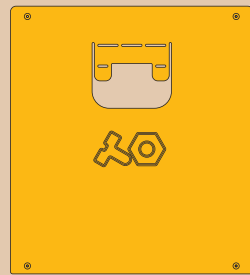

**C**

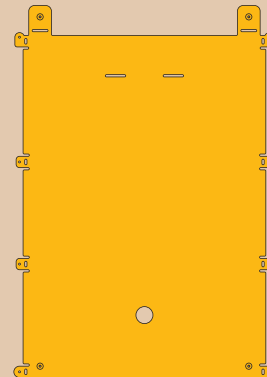

**D**

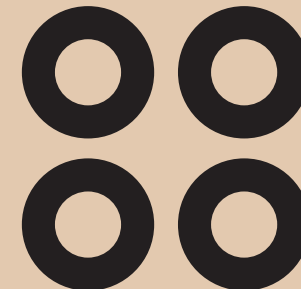
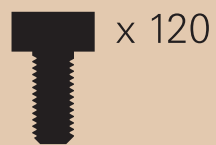
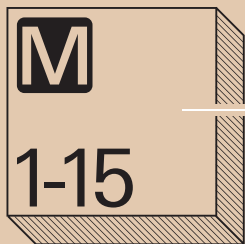
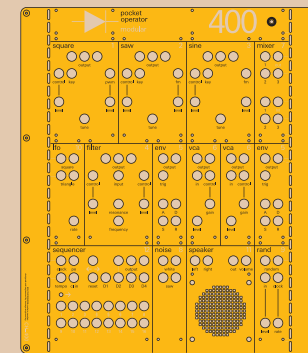

**A**

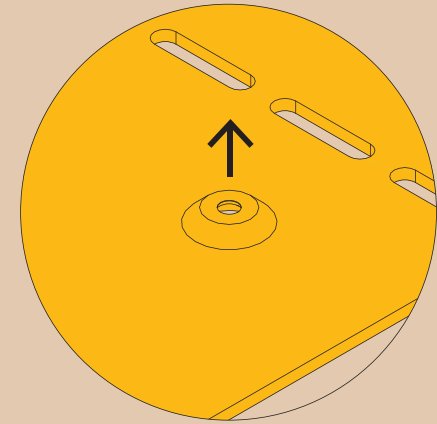
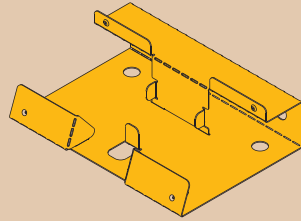
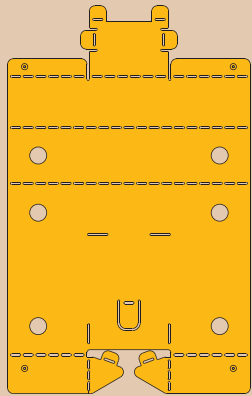

**1**

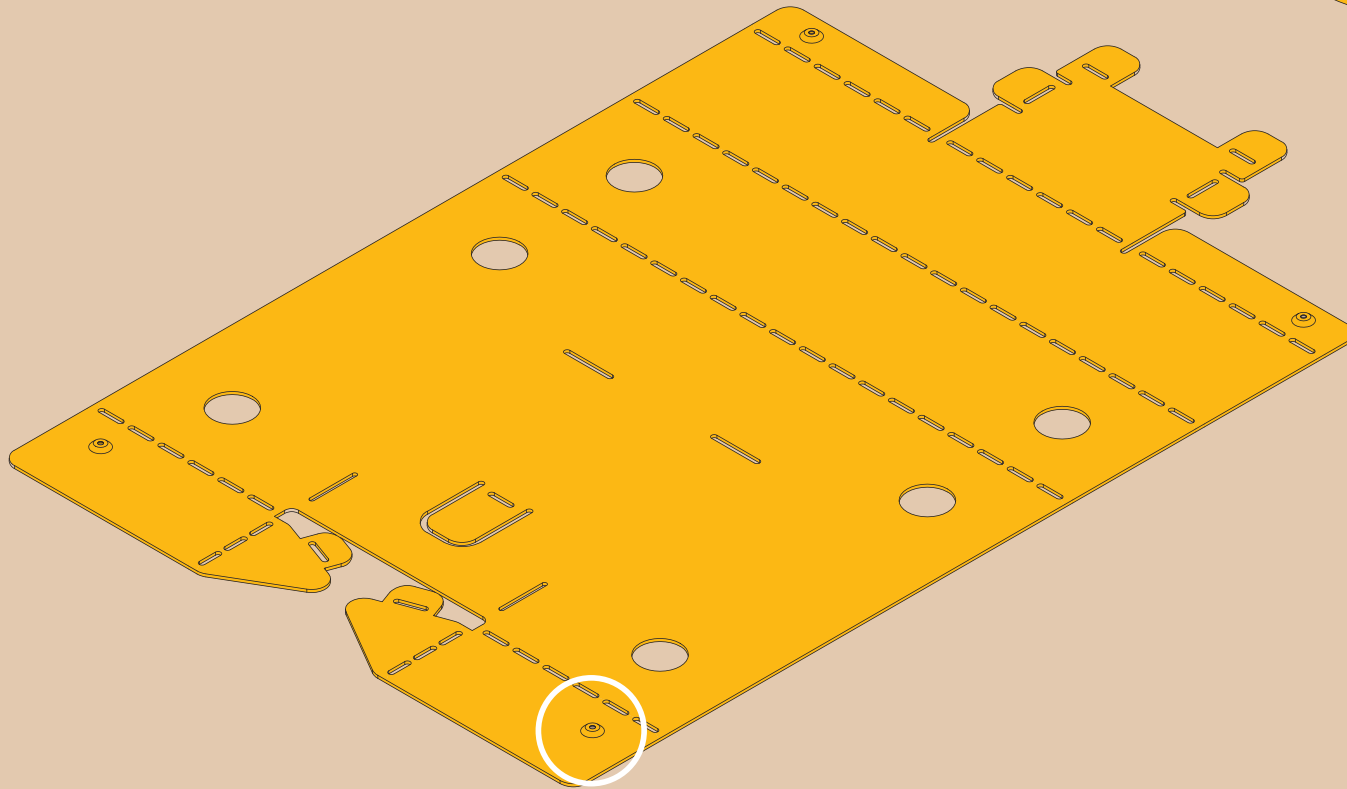

2

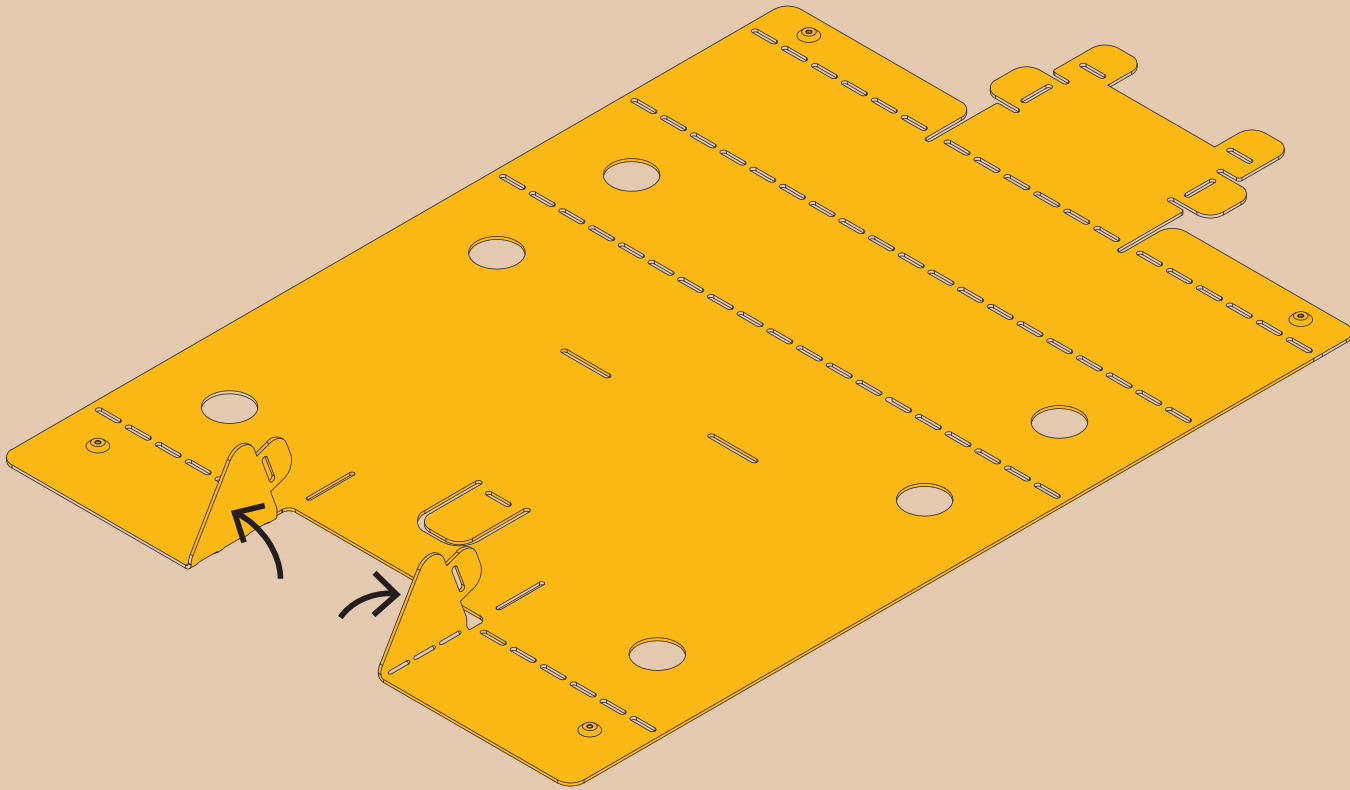

3

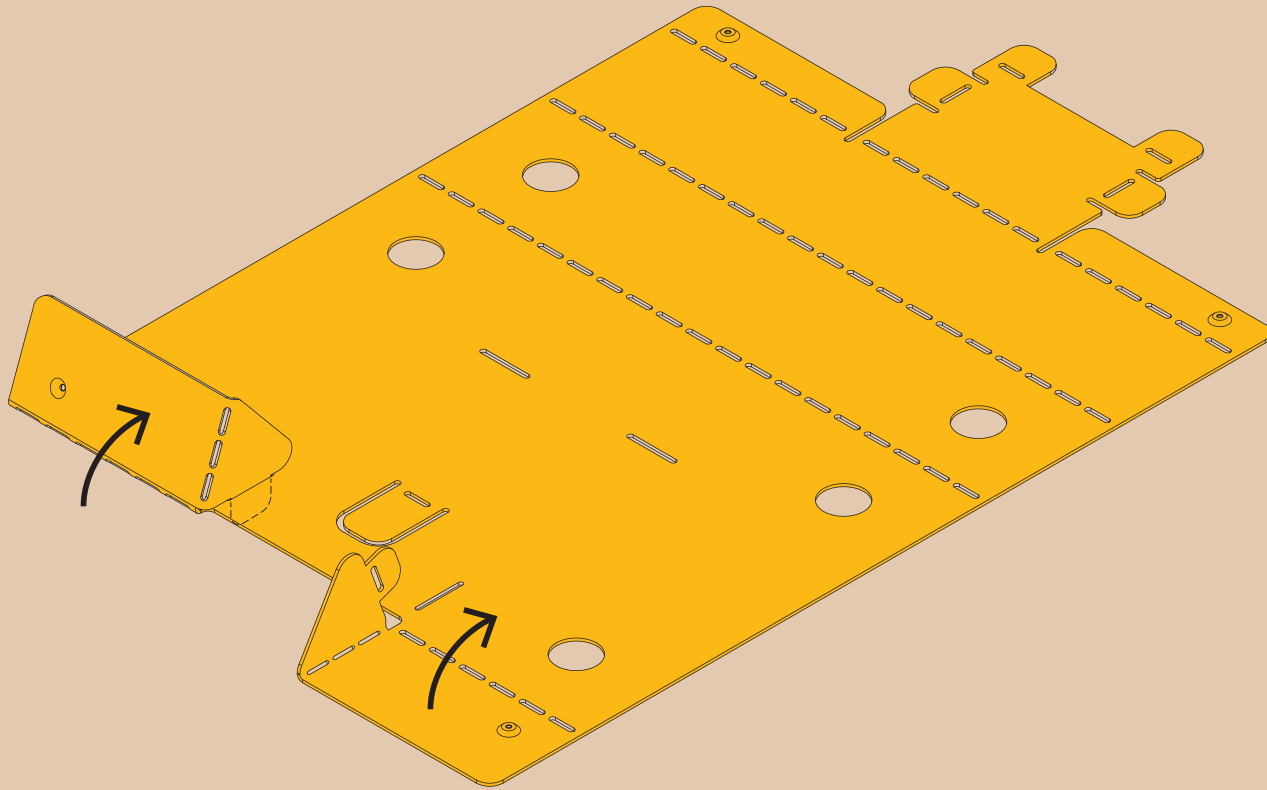



4

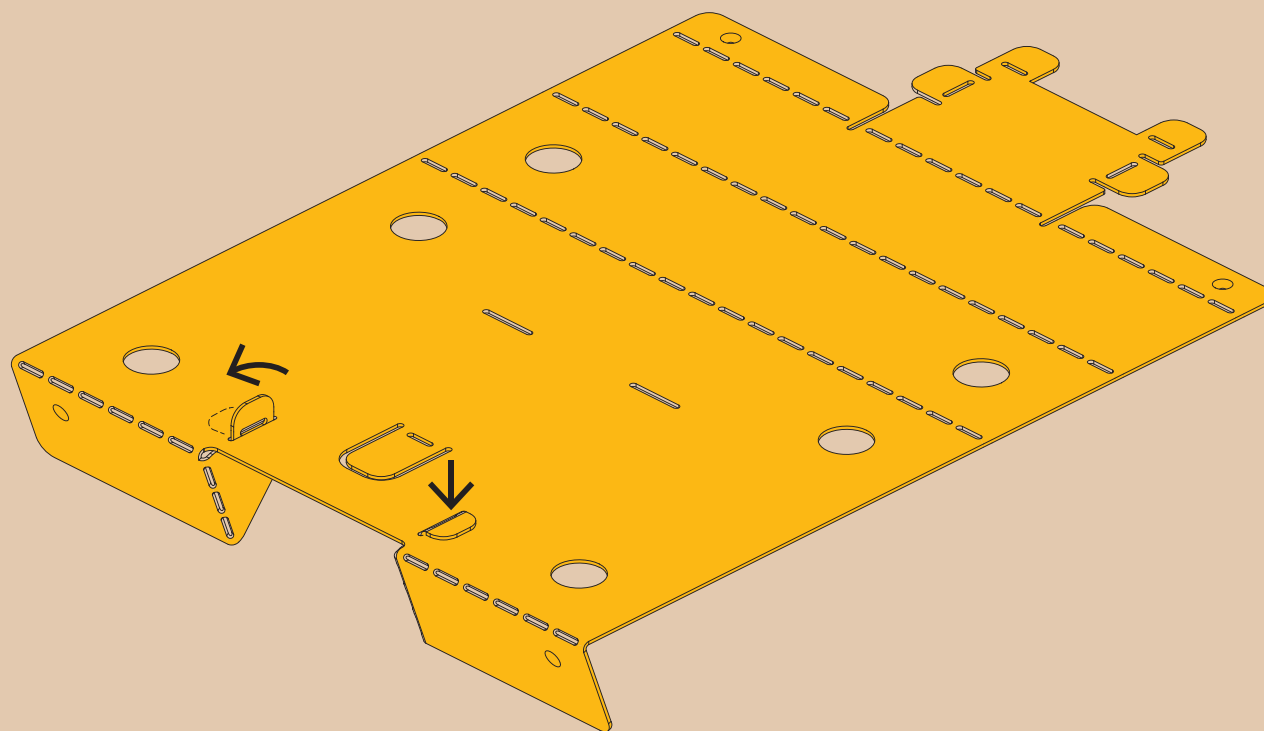

5

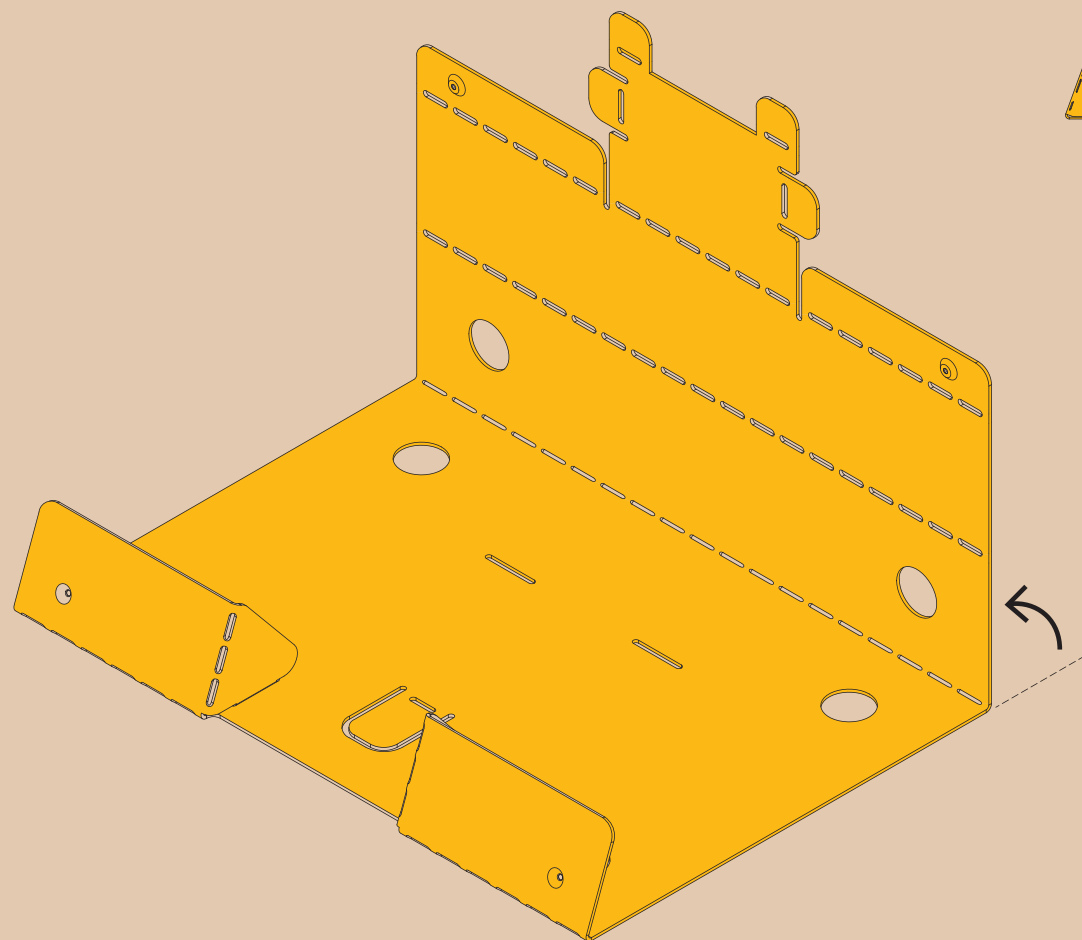

6

1-7 90°

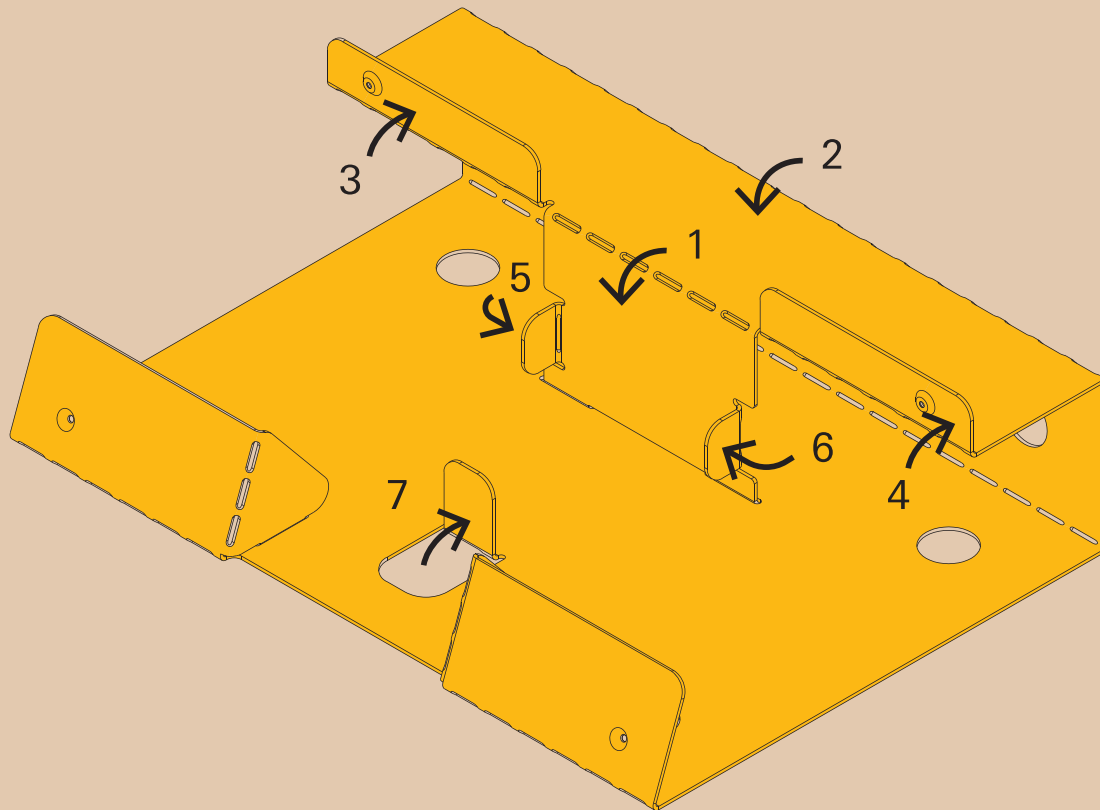

7

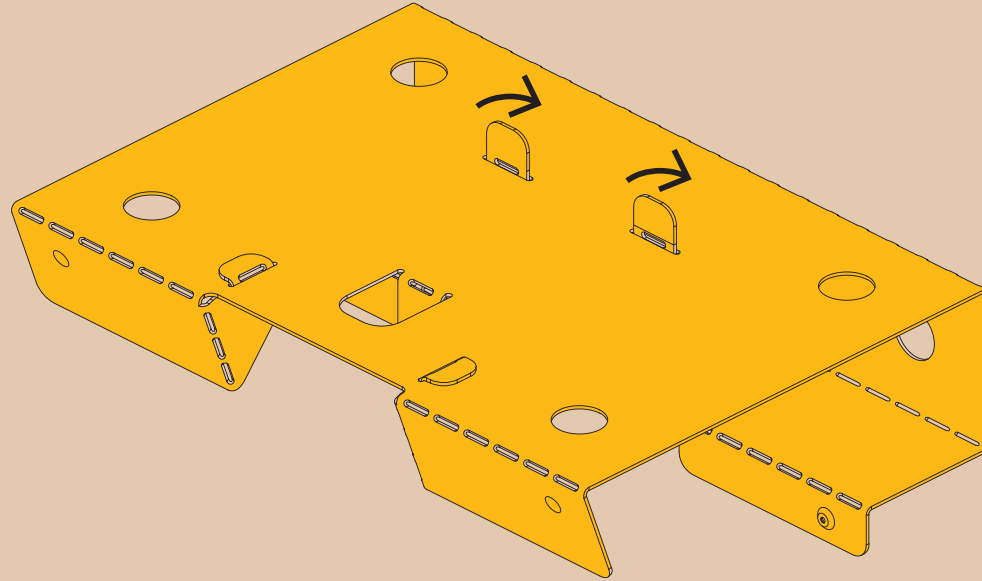

8

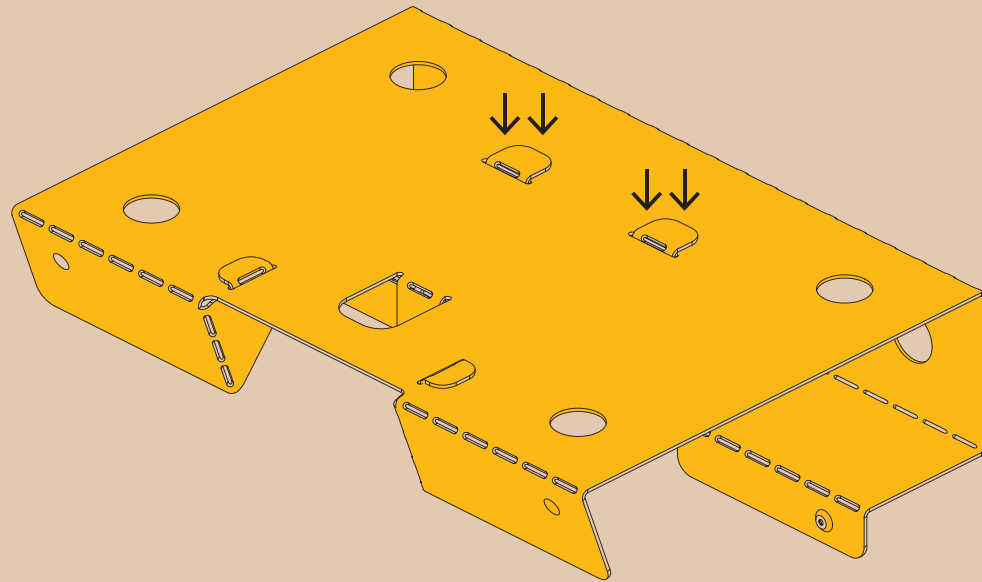

**B**

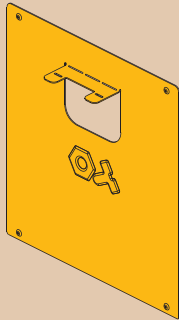
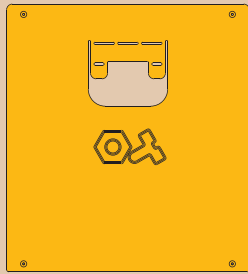

9

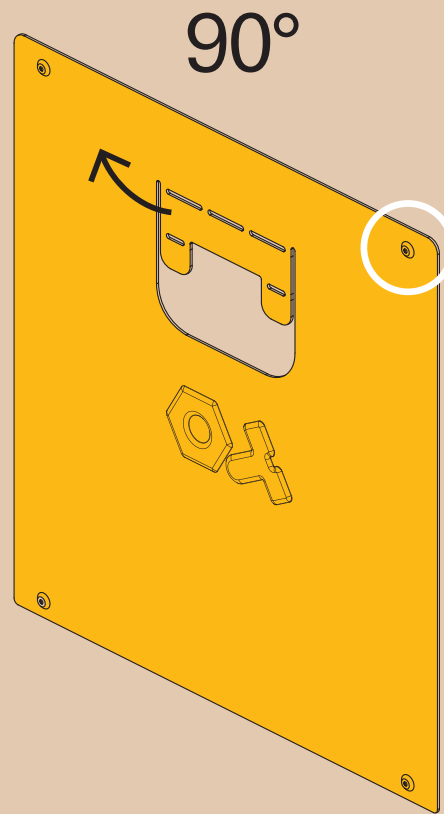
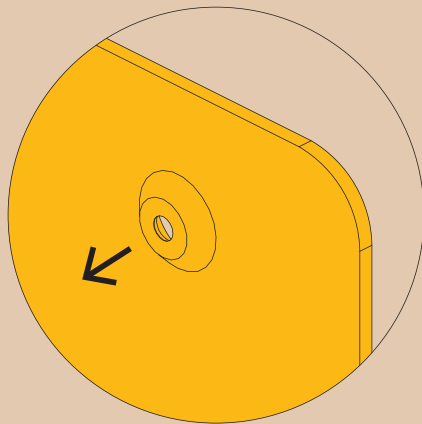

# 10

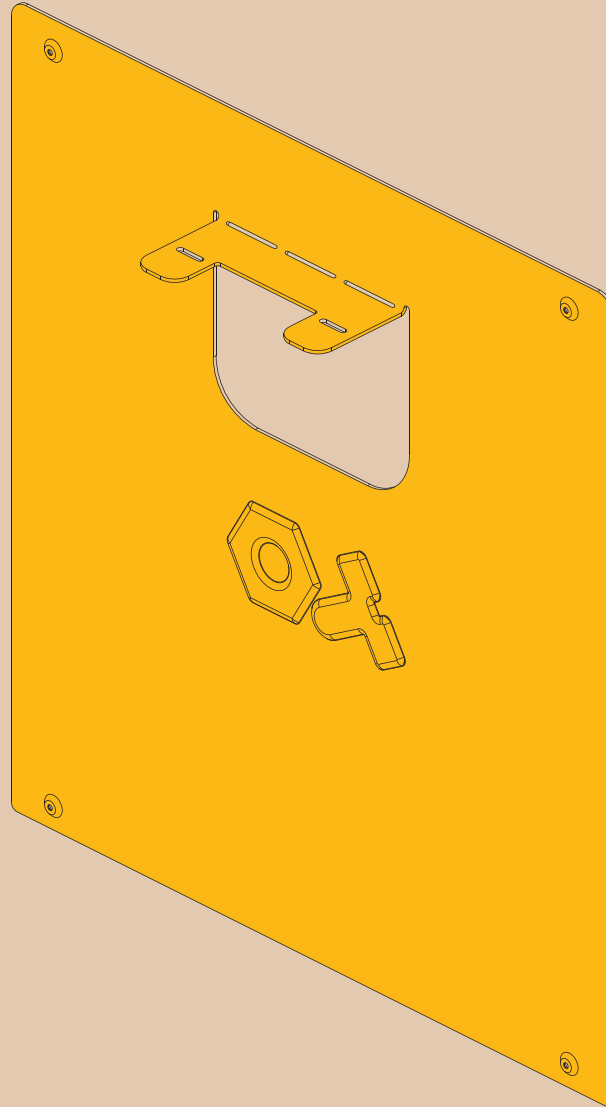

**C**

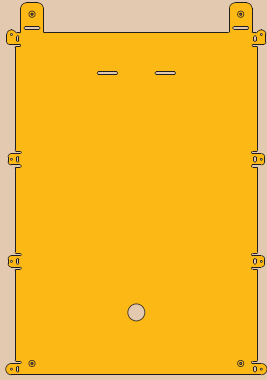

11

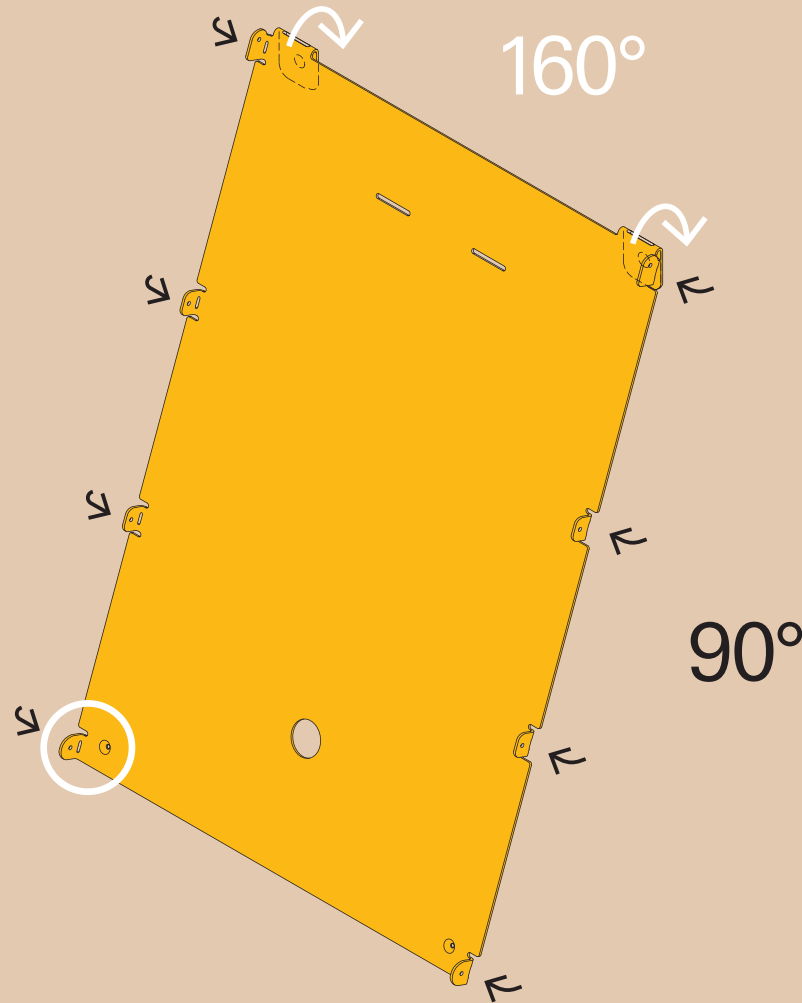
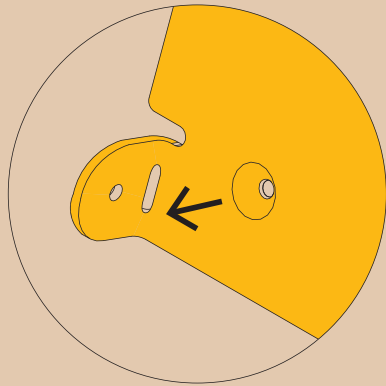

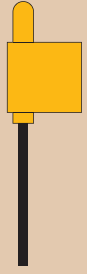

x 2

12

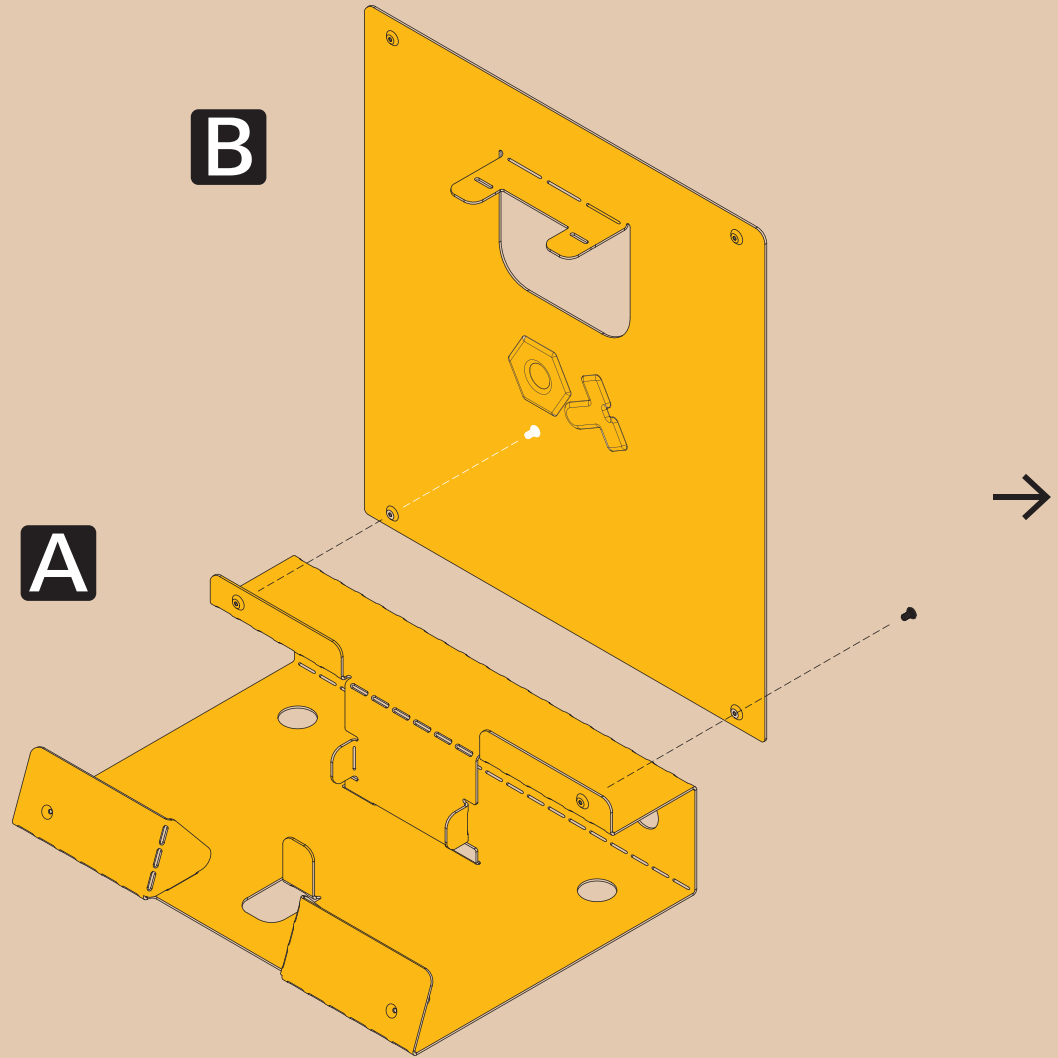



# 13



## B

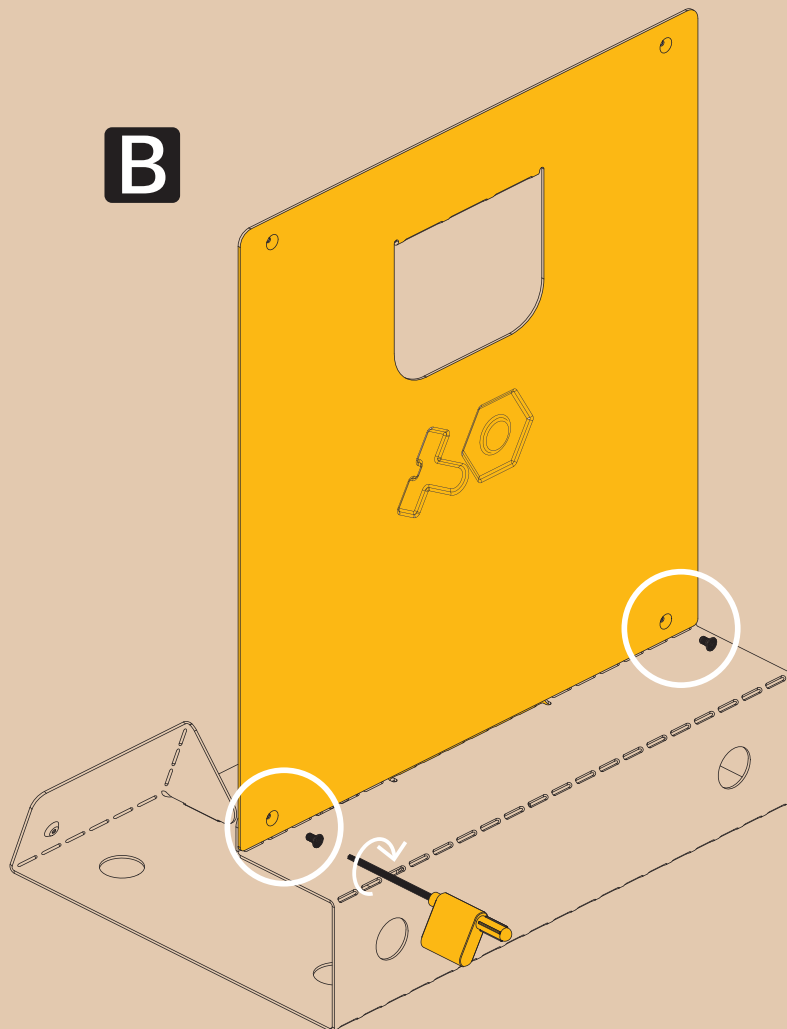

do not over tighten screws  
schrauben nicht zu fest anziehen  
ne pas trop serrer les vis  
non stringere troppo le viti  
ネジを締めすぎないようにご注意ください

# 14

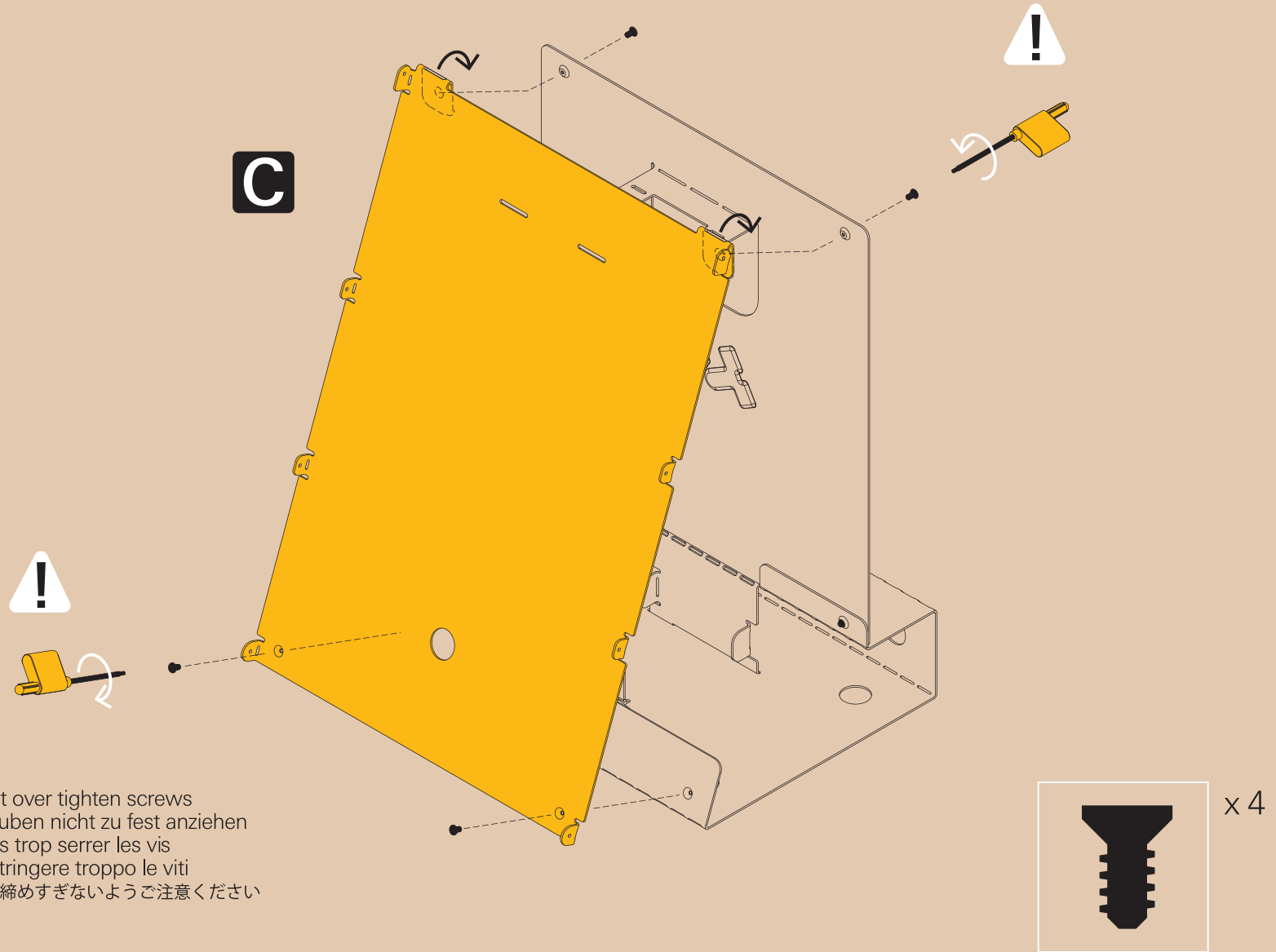

do not over tighten screws  
schrauben nicht zu fest anziehen  
ne pas trop serrer les vis  
non stringere troppo le viti  
ネジを締めすぎないようにご注意ください

# 15

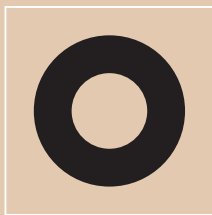
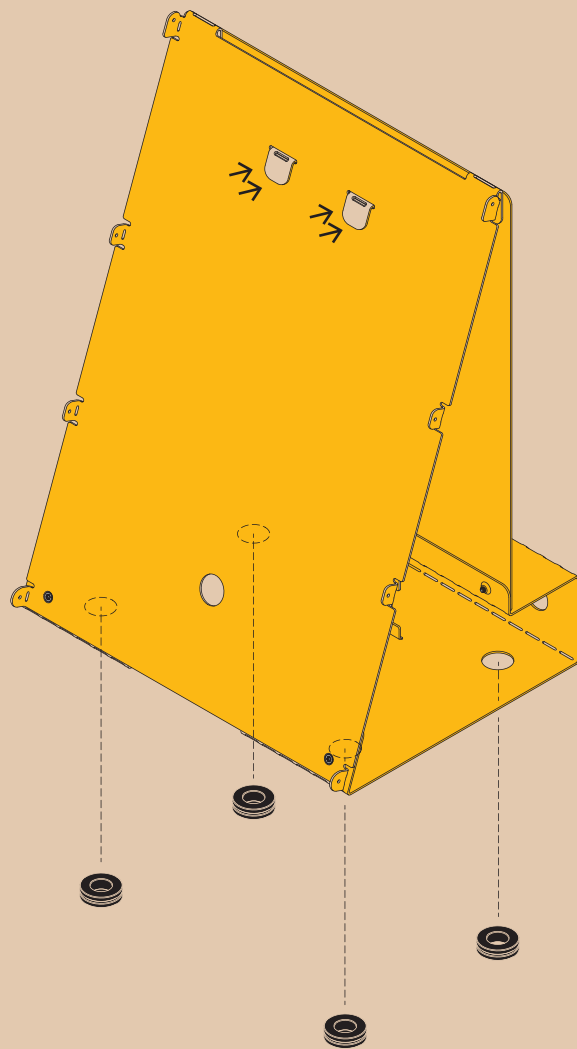

x 4



D

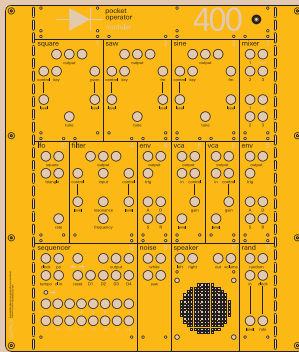

16

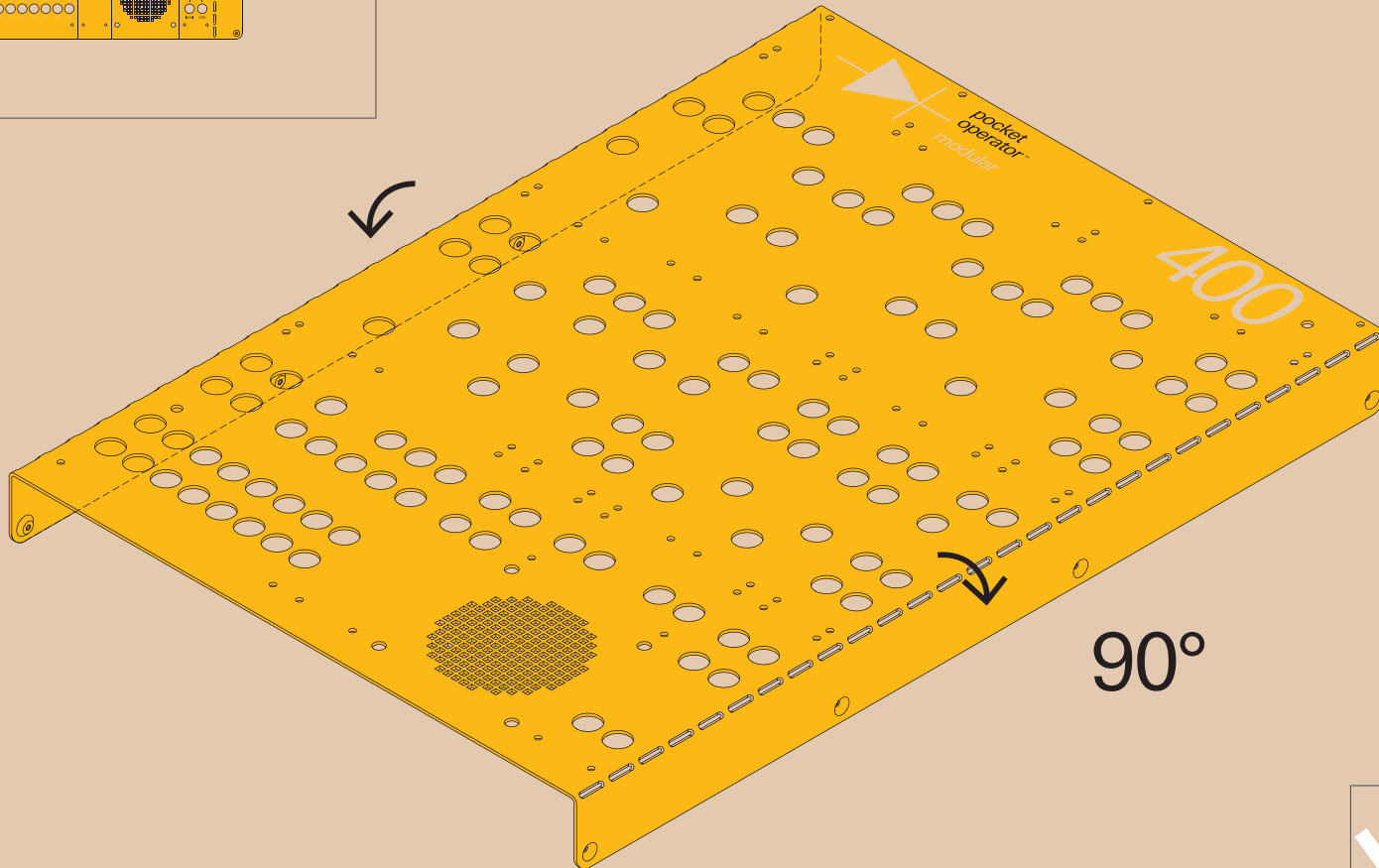

assembly

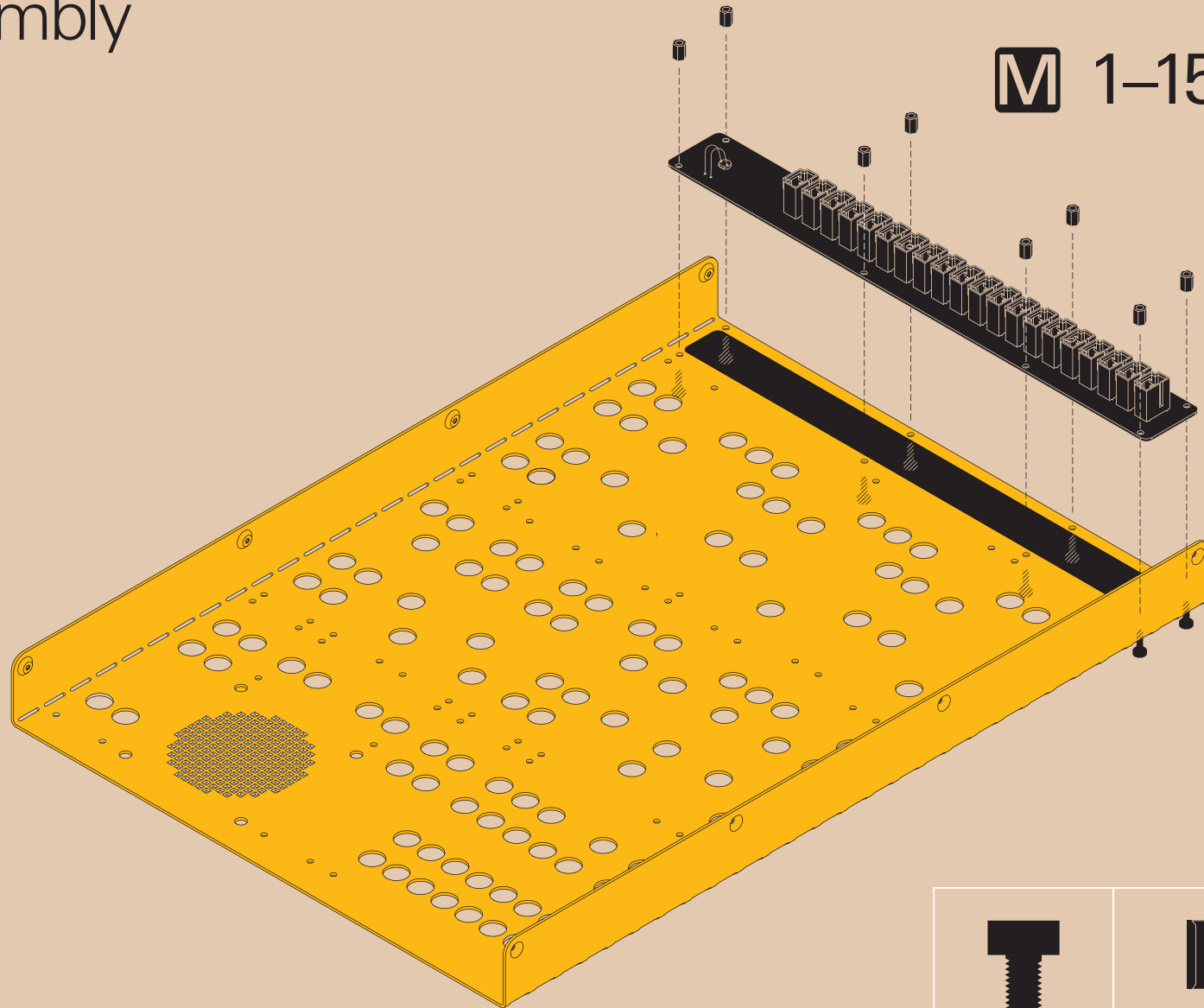

**M** 1-15

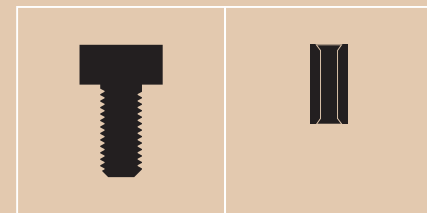

# module assembly

same principle  
for 170 & 400

# 1

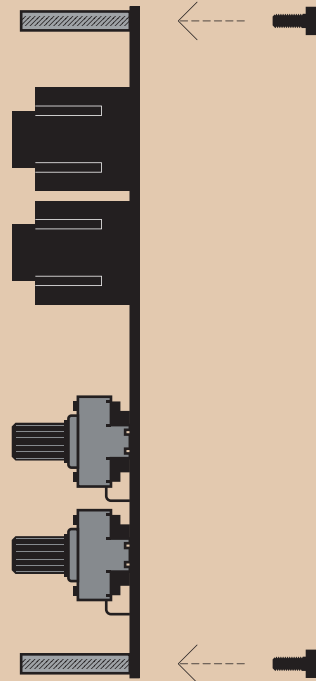

# 2

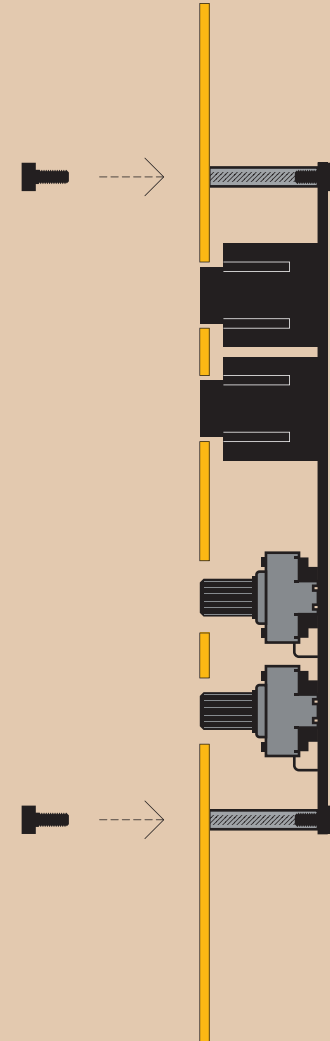

3

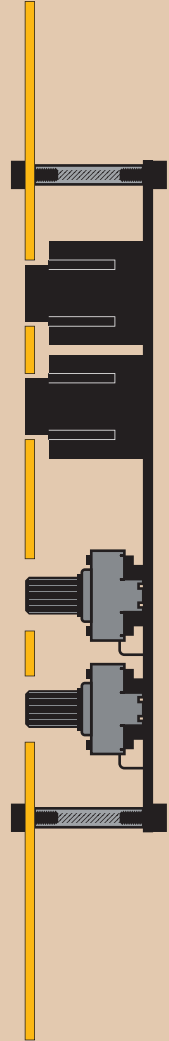
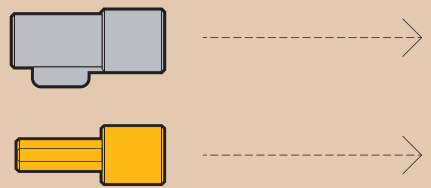

4

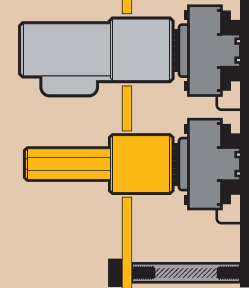

# speaker assembly

# 1



recycle square part  
quadratisches teil recyceln  
retirer la partie carrée  
ricicla la parte quadrata  
スピーカーモジュールから正方形のパーツを  
キレイに折って外します。



2

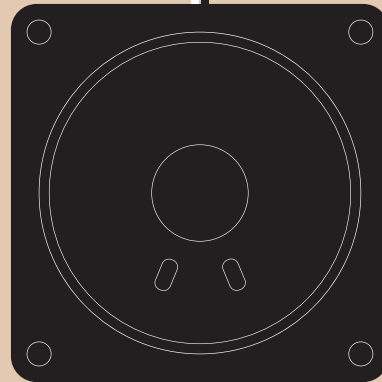
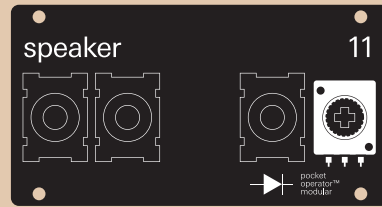

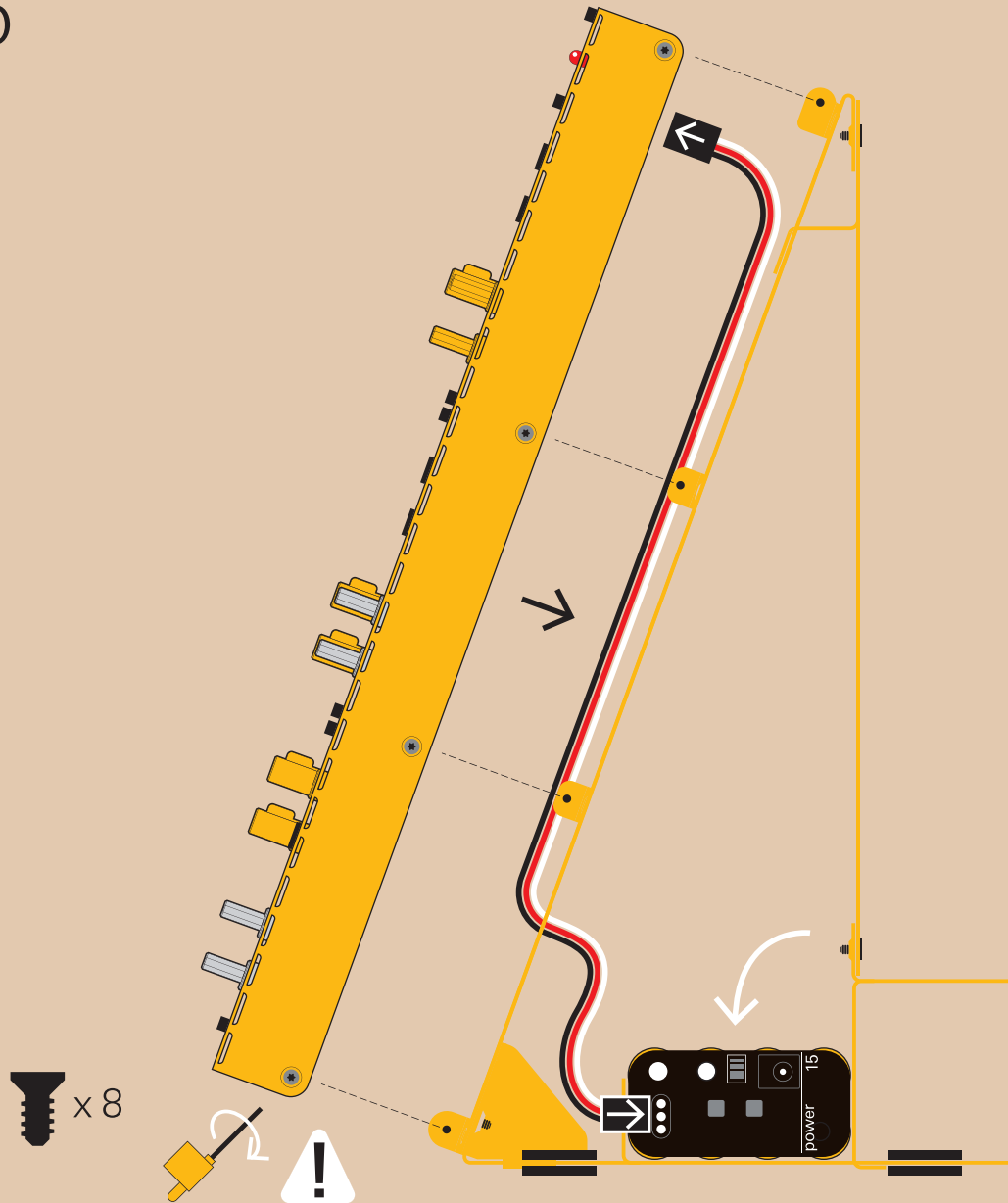

# stack up

same principle  
for 170 & 400

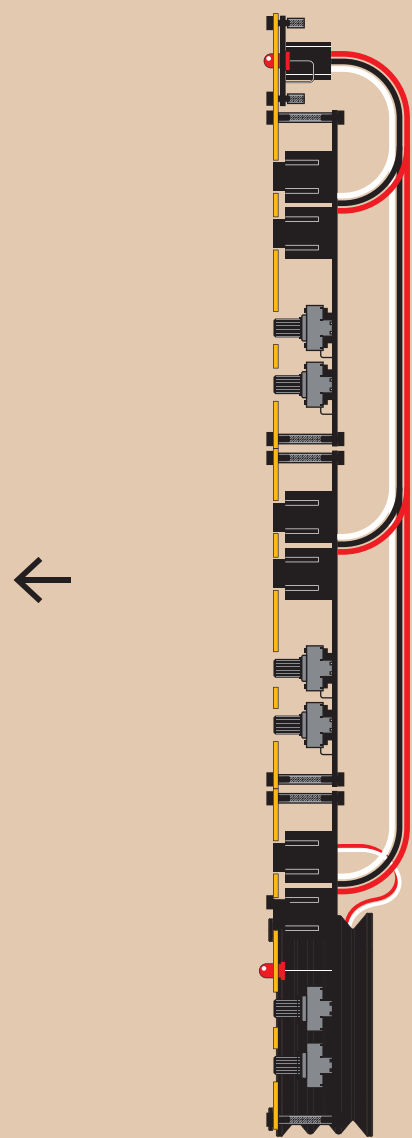
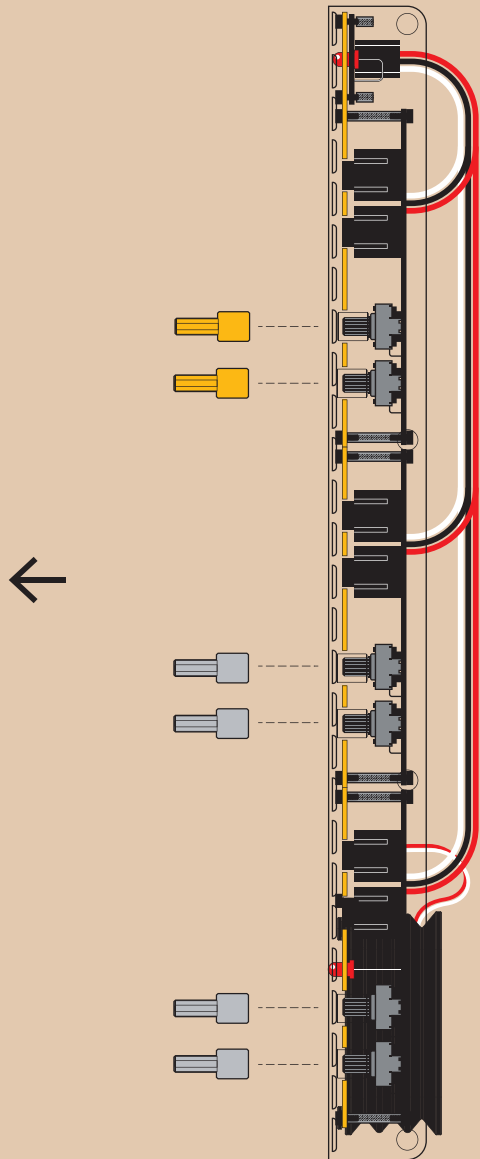

do not over tighten screws  
schrauben nicht zu fest anziehen  
ne pas trop serrer les vis  
non stringere troppo le viti  
ネジを締めすぎないようにご注意ください



**M**   
module  
assembly

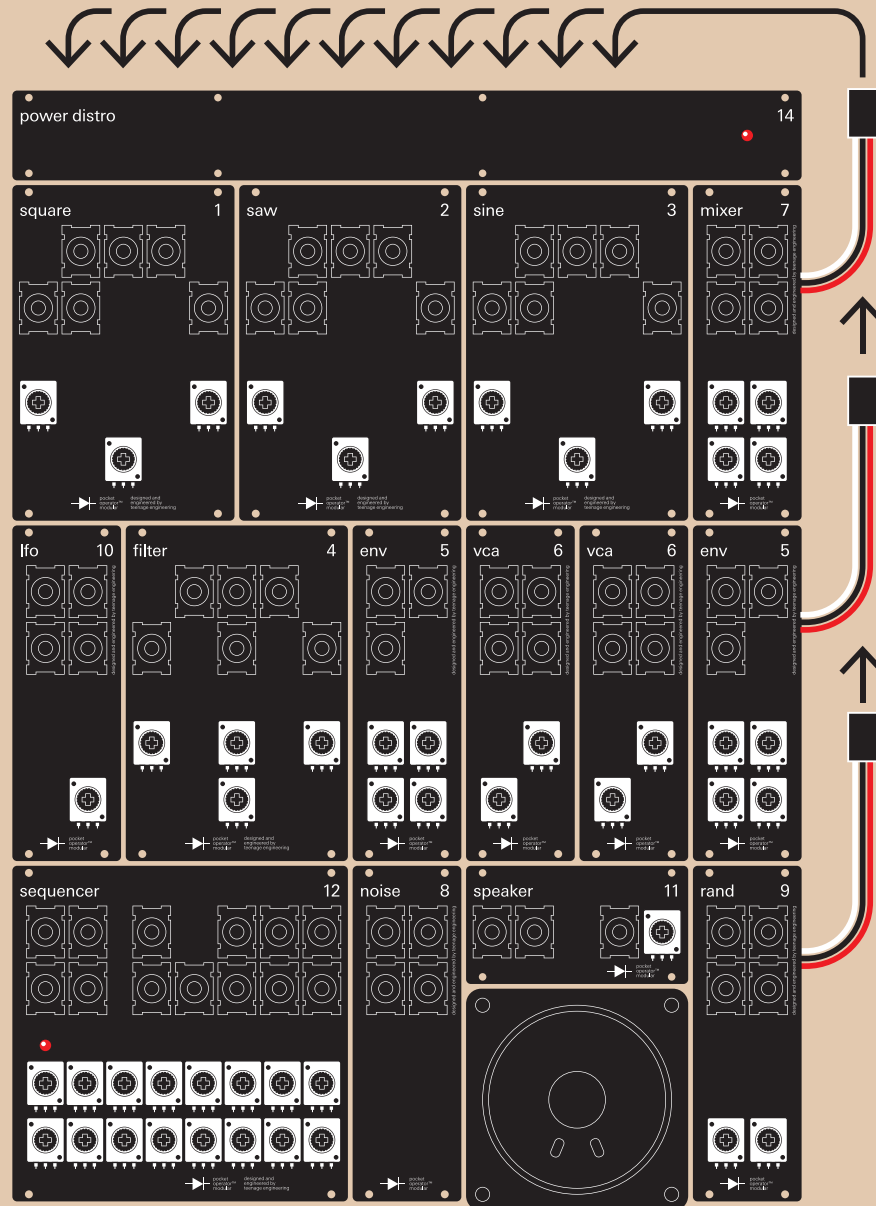

start with power distro  
and work downwards

beginne mit power distro und  
arbeite weiter nach unten

commencer le montage par  
le module 'power distro' et  
continuer vers le bas

inizia con il modulo power  
distro e lavora verso il basso

まずは電源分配器にケーブルを  
それぞれ接続します。  
それぞれのケーブルを下から  
電源分配器に接続してください

# knob color layout

align all encoders to left before mounting the knobs to get the correct indication

richte alle encoder vor der montage nach links aus um die korrekte anzeige zu erhalten

aligner tous les encodeurs à gauche avant de monter les boutons pour obtenir l'indication correcte

allinea tutti gli encoders a sinistra prima di montare i pomelli per ottenere la corretta indicazione

すべてのエンコーダを左揃えにします。ノブ取付前に正しい方向にしてください。

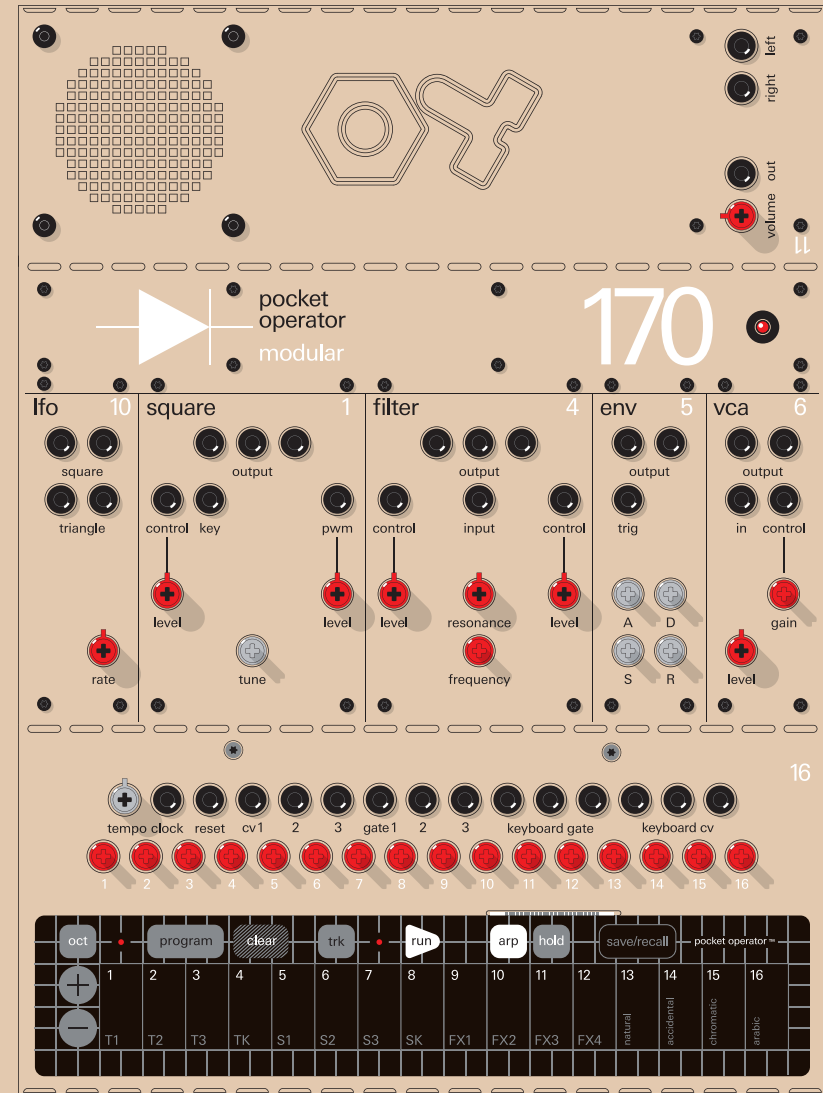
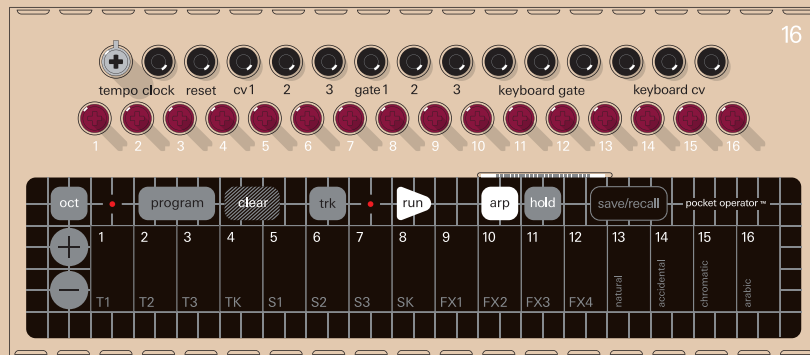

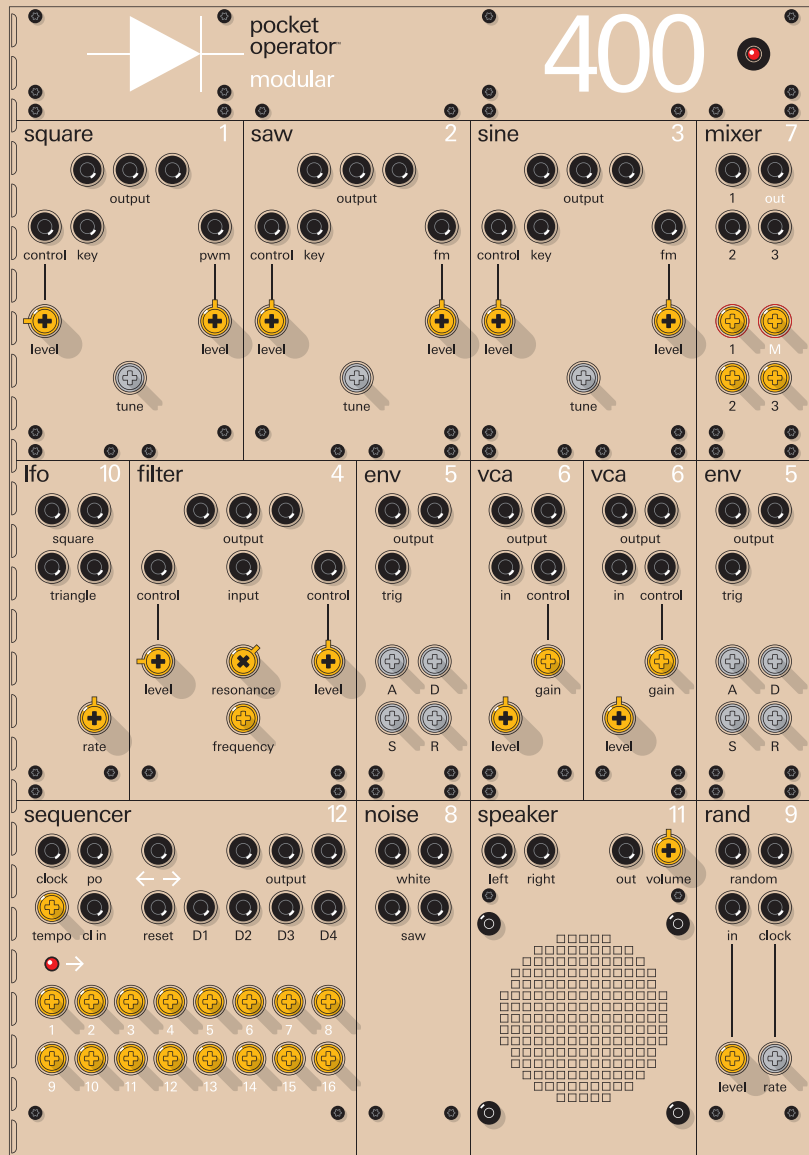

16



170



400

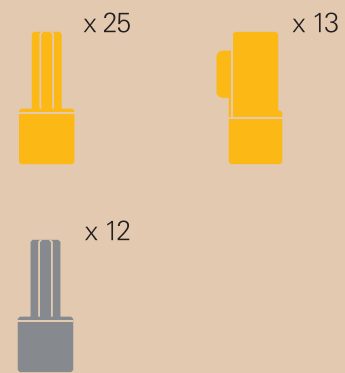

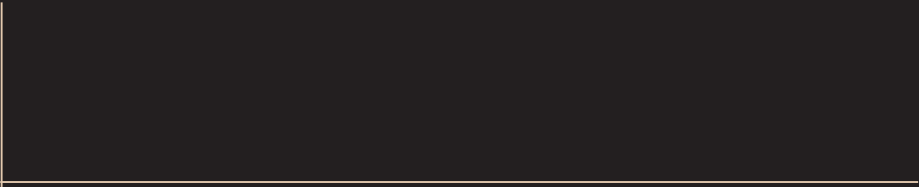
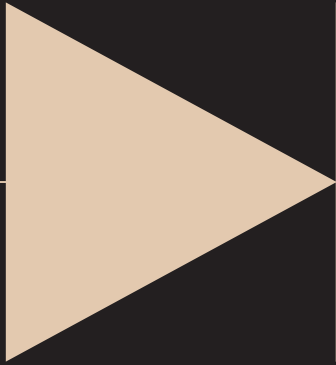

M

# M

## 1

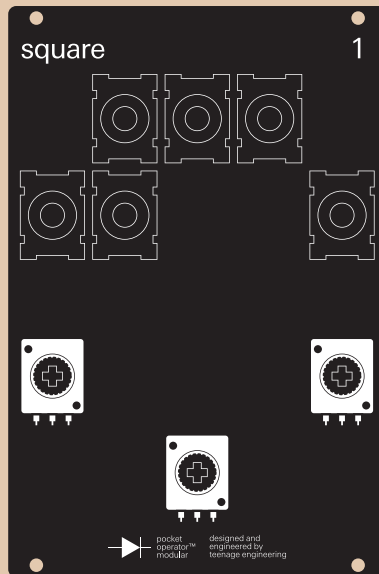

### square

square oscillator

rich in odd harmonics, the square wave oscillator is great for hollow basses and screaming leads. the pulse width modulation (pwm) input makes it possible to generate a faux two oscillator detune sound.

## 2

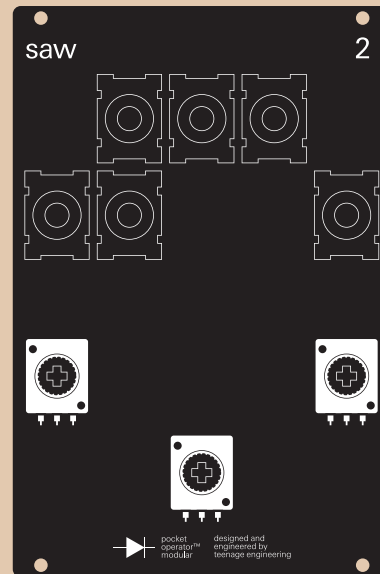

### saw

sawtooth oscillator

containing both the odd and even harmonics, the sawtooth is great for string types of sound. the linear frequency modulation input (fm) easily brings you into the sci-fi domain.

## 3

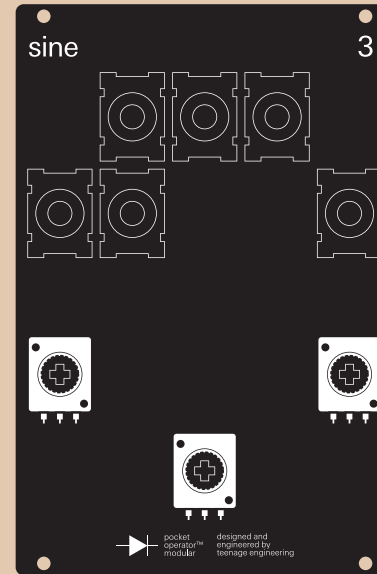

### sine

sine oscillator

with no overtones the pure sine wave is a jack of all trades. from pure bass to dub sirens, it's the army knife of a modular system. the linear frequency modulation input (fm) easily brings you into the sci-fi domain.

## 4

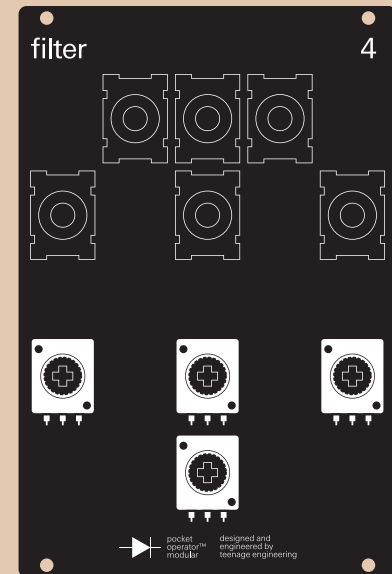

### filter

low pass filter

shape your sound with the 24db/oct low pass filter. get lost in space while tweaking the resonance and frequency pots..



# 5

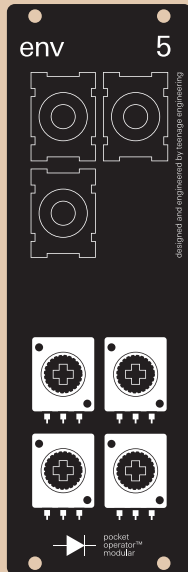

## env

envelope

a classic. attack, decay, sustain and release. give your sonic creation the contour it deserves. triggered by any signal that crosses the two volt threshold.

# 6

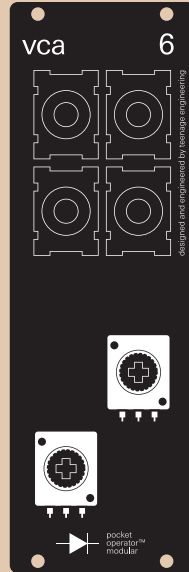

## vca

voltage control amplifier

automate your volume! feed it control voltage and your signal will adapt accordingly. best friends with the envelope for classic configurations, and your oscillator in wired configurations.

# 7

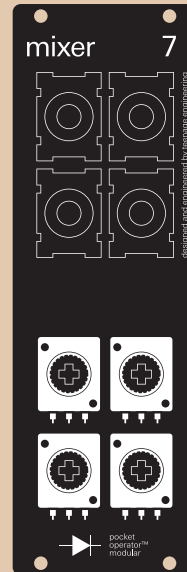

## mixer

3-channel mixer

a necessity in all modular systems. three inputs, one output with volume control over both the individual inputs as well as the master output.

# 8

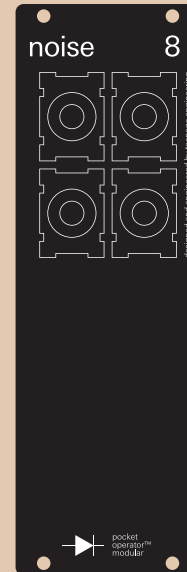

## noise

2 x noise

the white noise contains noise equal over the whole spectrum. the saw output is a perfect companion to the sample and hold.

# M

## 9

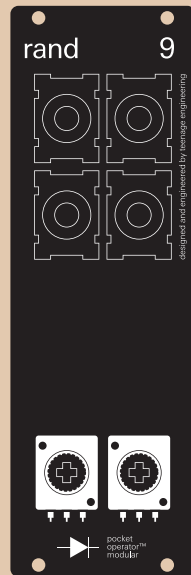

### rand

randomise your music with the sample and hold. any input is sampled and then presented at the outputs. rate can be controlled both externally and internally, but always needs an external signal to sample. experiment with both receptive and random sources as the sample input.

## 10

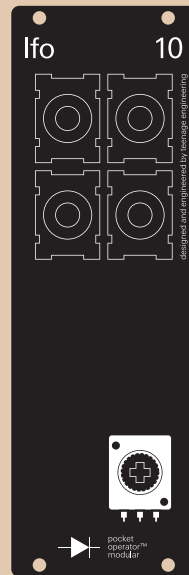

### lfo

low frequency oscillator generating both square as well as triangle waves, the low frequency oscillator is the perfect tool to spice up your patches. great in everything from automated filter sweeps to syncing the clocks.

## 11

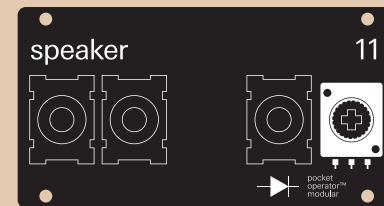

### speaker

amplifier + speaker bellow

cables go in, sounds come out. show off your amazing patch to the rest of the world. let them hear it. warning: never connect headphones directly to the outputs! you can damage your ears and your headphones.

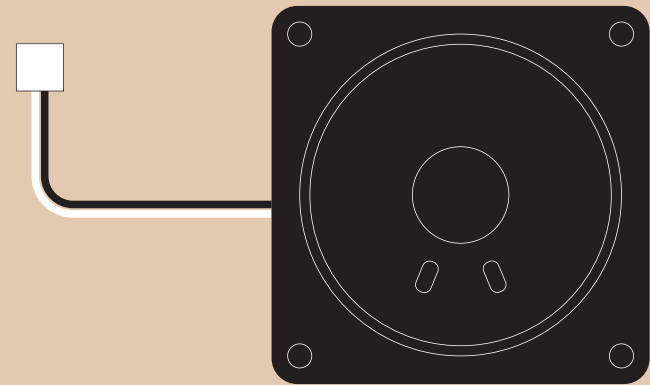

# 12

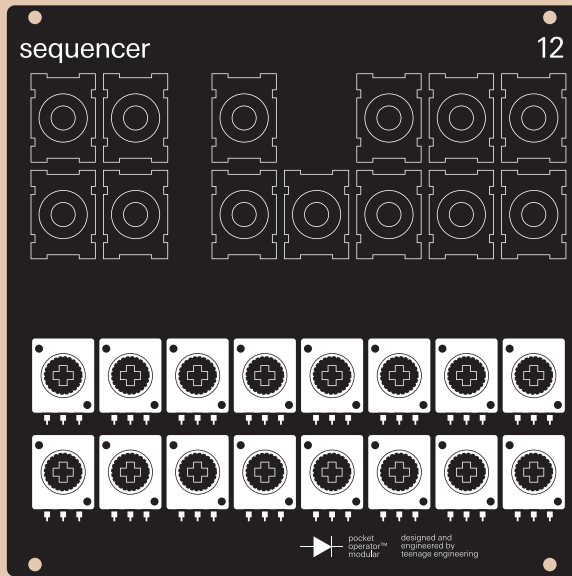

## sequencer

16-step sequencer

sixteen steps of control. override the internal clock with the clock input. send clock out or po sync out. make it go backwards with the arrow input. jump to the first step, the second, fourth or eight step with the reset and binary

inputs. or just reset it to the first step by setting any stage pot to max.

# 13



## mystery module

number 13

won ton 'animal' chin entered the modular scene with this unit back in the late 80s during a skate / modular retreat. the rumor says that this module will never be for sale, just given away at special outdoor gatherings.

# 14



## power distro

20 unit power hub

the central nervous system and the connection hub for all the power. bend the led 180° and fit it through the hole to get front panel light action.

# M

# 15

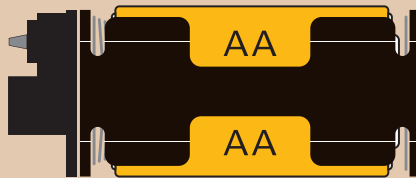
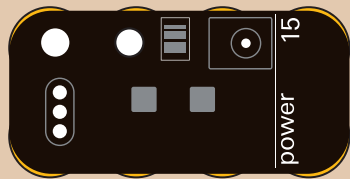

## psu

power pack

small, portable, battery powered. delivers plus and minus twelve volts to support your favorite system. use with 8 AA batteries or external power supply.

# 16

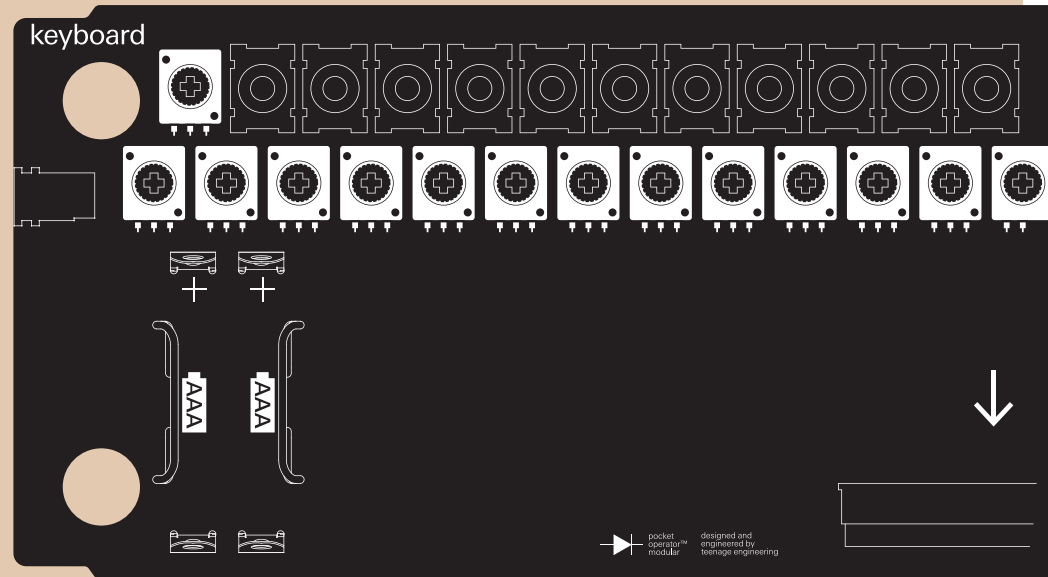

## keyboard

16-note membrane keyboard

the perfect interface to control your 170 and 400 systems!

play notes and program patterns using the keyboard and use the knobs to control cv.

patch the cv / gate outputs to your other operator modular units or to any other compatible device. use po sync to synchronize pocket operators, and use the midi out to control any midi gear.

# box content

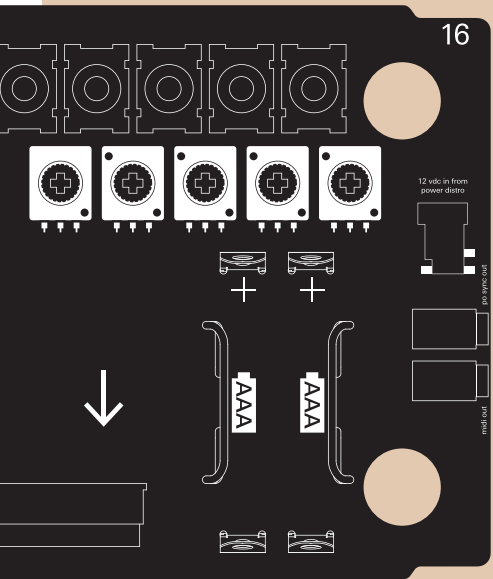

the internal clock can be overridden with an external clock input.

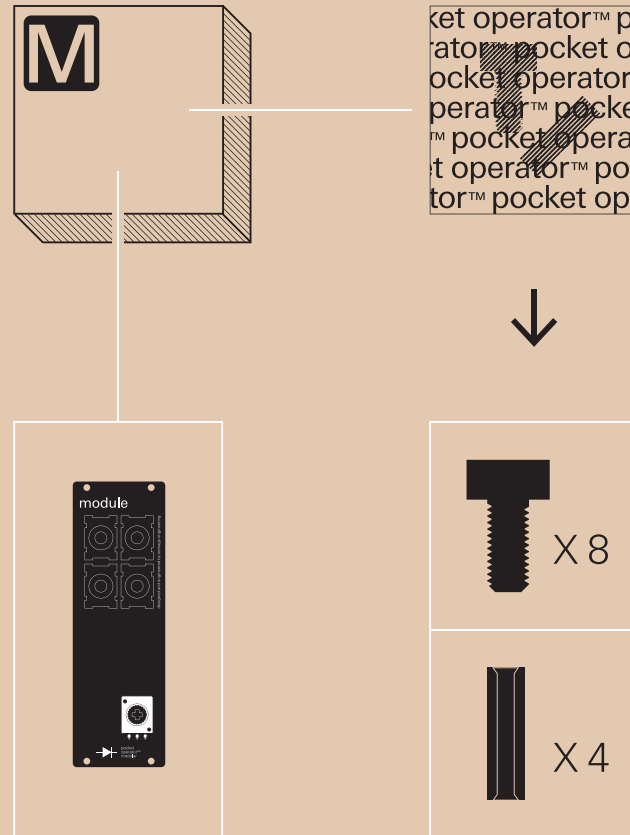

# keyboard

you can program the **16** to playback your recorded notes. this function is called a sequencer. please read the M-16 manual for complete instructions.

du kannst das po **16** modular so programmieren, dass es aufgenommene noten abspielt. diese funktion wird sequenzer genannt. bitte lese das M-16 handbuch für eine komplette anleitung.

vous pouvez programmer le **16** pour lire vos notes enregistrées. cette fonction est appelée séquenceur. veuillez lire le manuel du M-16 pour des instructions complètes.

è possibile programmare il **16** per riprodurre le note registrate. questa funzione è chiamata sequencer. si prega di leggere il manuale dell'M-16 per istruzioni complete.

16番をプログラムすることで、レコーディングされたノートを再生することができます。これはシーケンサーと呼ばれる機能です。詳しくは、M-16のマニュアルを読んでください。

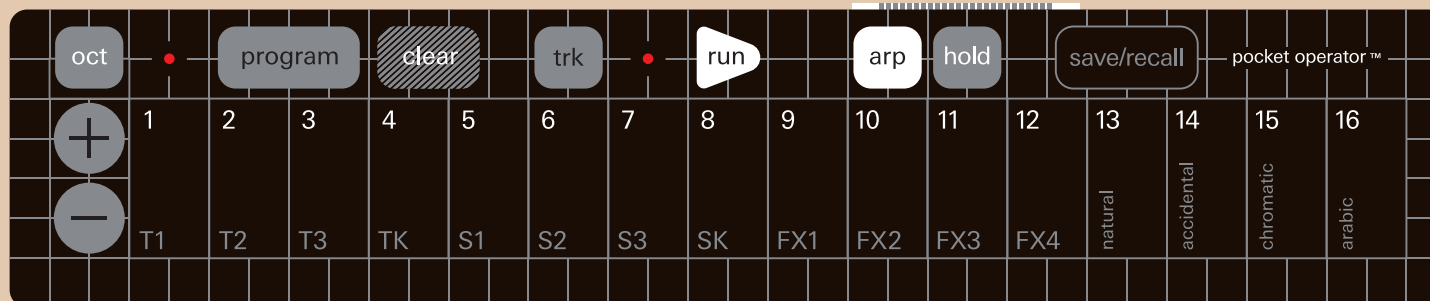

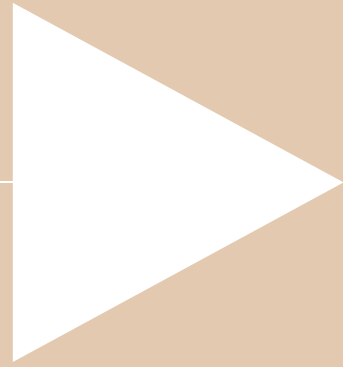

patches

# let's patch

in a modular synthesizer, you can patch anything anywhere. don't worry, nothing will break if you do it wrong. in fact, there is no wrong, but not everything you patch will be musically useful, that's up to you to decide. real-time hands-on experimentation is the greatest part about modulators. it will change your mind and your soul. here are some examples of patches to get you started. output to output connections are not recommended.

in einem modularen synthesizer kannst du alles an jeden ort patchen. keine sorge, es geht nichts kaputt, wenn du etwas falsch machen. eigentlich gibt es kein falsch, aber nicht alles, was du verbindest, wird musikalisch nützlich sein, das entscheidest du alleine. echtzeit-experimente sind der größte bestandteil modularer synthesizer. es wird dein bewusstsein und deine seele verändern. hier sind einige beispiele für patches, um dir den start zu erleichtern. verbindungen von ausgang zu ausgang werden nicht empfohlen.

dans un synthétiseur modulaire, vous pouvez patcher n'importe où. ne vous inquiétez pas, rien ne se cassera si vous le faites mal. en fait, il n'y a pas de problème, mais tout ce que vous corrigez ne sera pas utile sur le plan musical, à vous de décider. l'expérimentation pratique en temps réel est la partie la plus importante des modules. cela changera votre esprit et votre âme. voici quelques exemples de correctifs pour vous aider à démarrer. les connexions de 'output' à 'output' ne sont pas.

in un sintetizzatore modulare, puoi applicare qualsiasi patch ovunque. non preoccuparti, nulla si romperà se sbagli. infatti, non c'è nulla di sbagliato, ma non tutto ciò che colleghi sarà utile musicalmente, sta a te decidere. la sperimentazione pratica in tempo reale è la parte più importante. cambierà la tua mente e la tua anima. ecco alcuni esempi di patch per iniziare. le connessioni output-output non sono consigliate.

モジュラー・シンセサイザーでは、あらゆるものをあらゆる場所へ自由にパッチングできます。ご心配なく、パッチを間違っても破損することはありません。実際のところ、間違いなどというものではなく、パッチしたものが音楽的に使えるとは限らない、ということです。これはあなたの決定にかかっています。リアルタイムかつハンズオンで実験できることこそがモジュラーの最も素晴らしい点であり、思考や魂をも変えてしまうものです。下記いくつかのパッチ例をご用意しましたので、ご参考ください。それぞれアウトプットは他のアウトプットには接続しないでください。





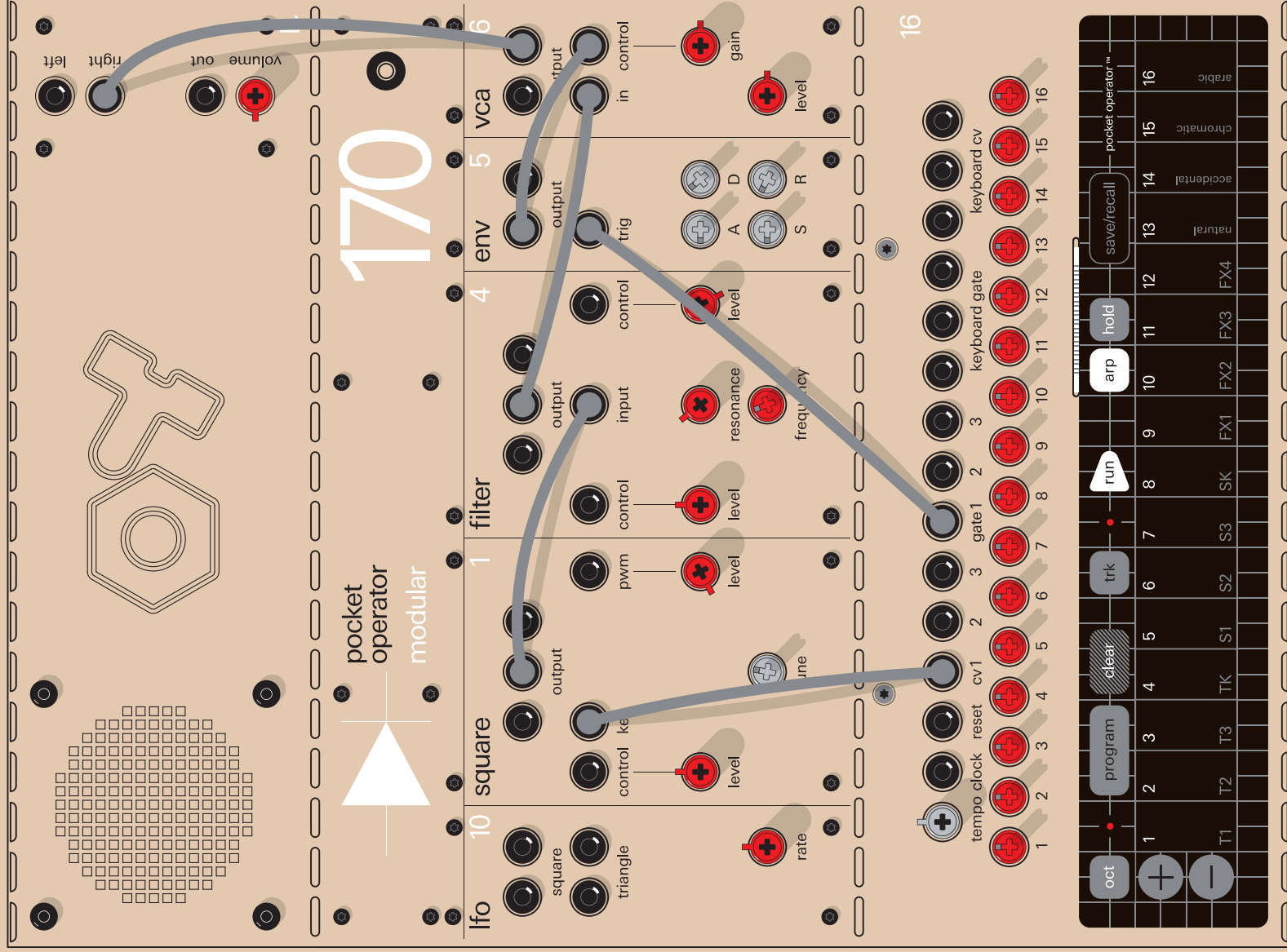

classic

patch note: play notes on the keyboard (1-16) and adjust env adsr settings.

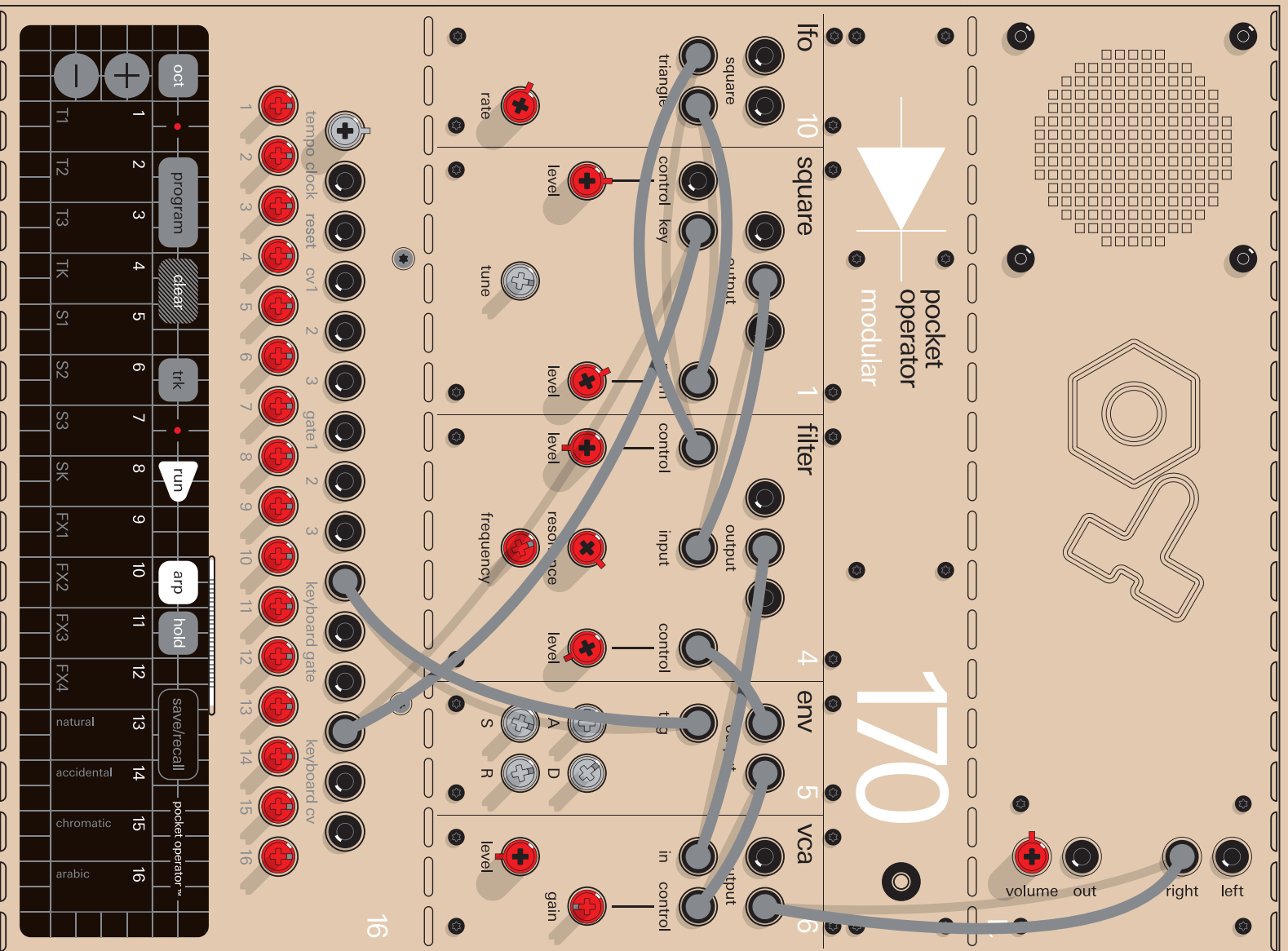

# 170

girth

patch note: hold tk and press **TK** to select the keyboard track. **program** a pattern by pressing **program**, 1-16 and **program** again. press **run** to start the pattern. listen to what happens when you turn filter rate and square pwm level.

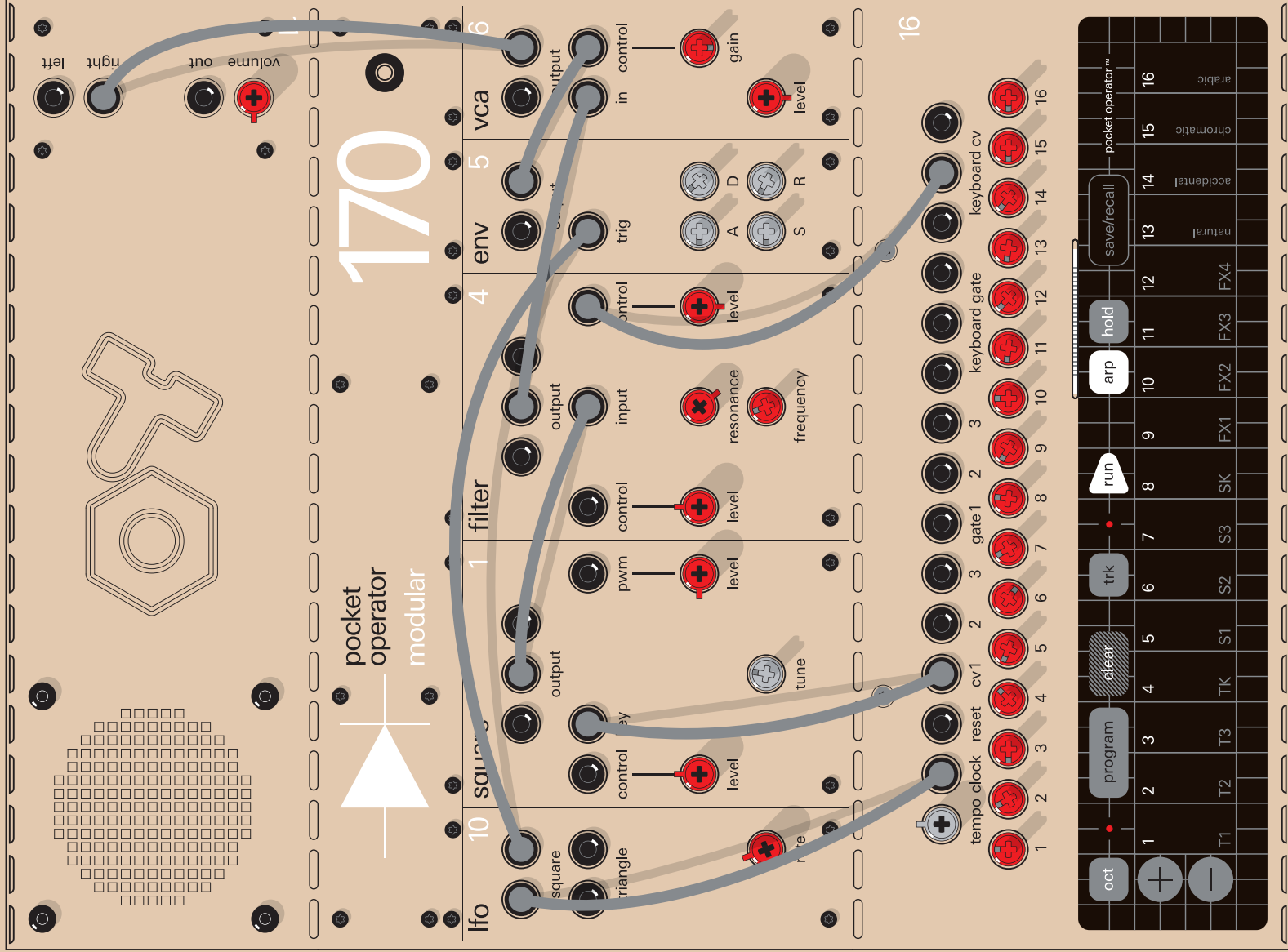

## autoplay

patch note: use lfo rate to control the autoplay speed. use cv1 to control pitch, and open and close the filter using the keyboard track (TK).

oct	program	clear	trk	run	arp	hold	save/recall	pocket operator™									
1	2	3	4	5	6	7	8	9	10	11	12	13	14	15	16		
T1	T2	T3	TK	S1	S2	S3	SK	FX1	FX2	FX3	FX4	natural	accidental	chromatic	arabic		

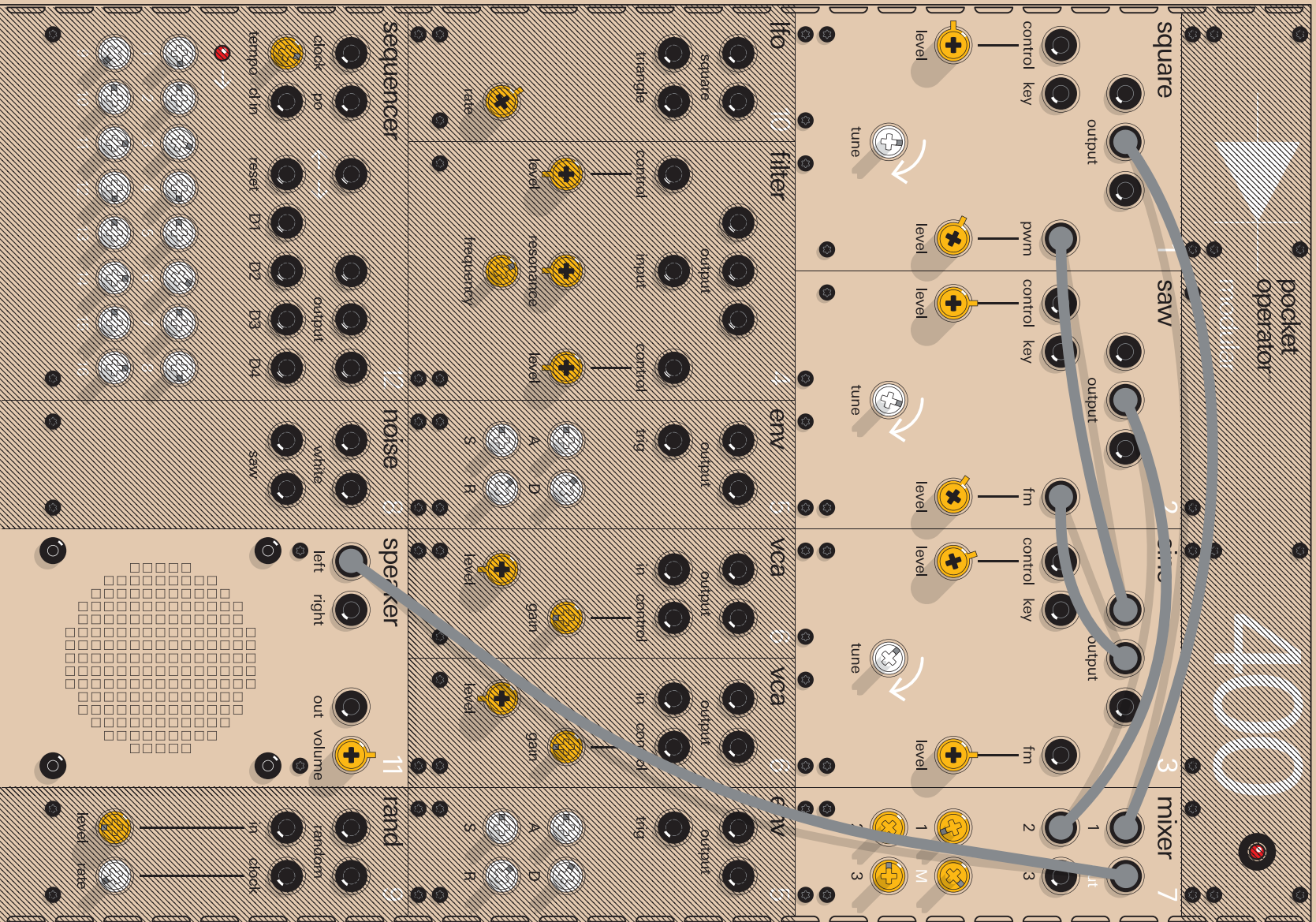

obese drone

patch note: start with square and saw oscillator tuned to the same frequency.



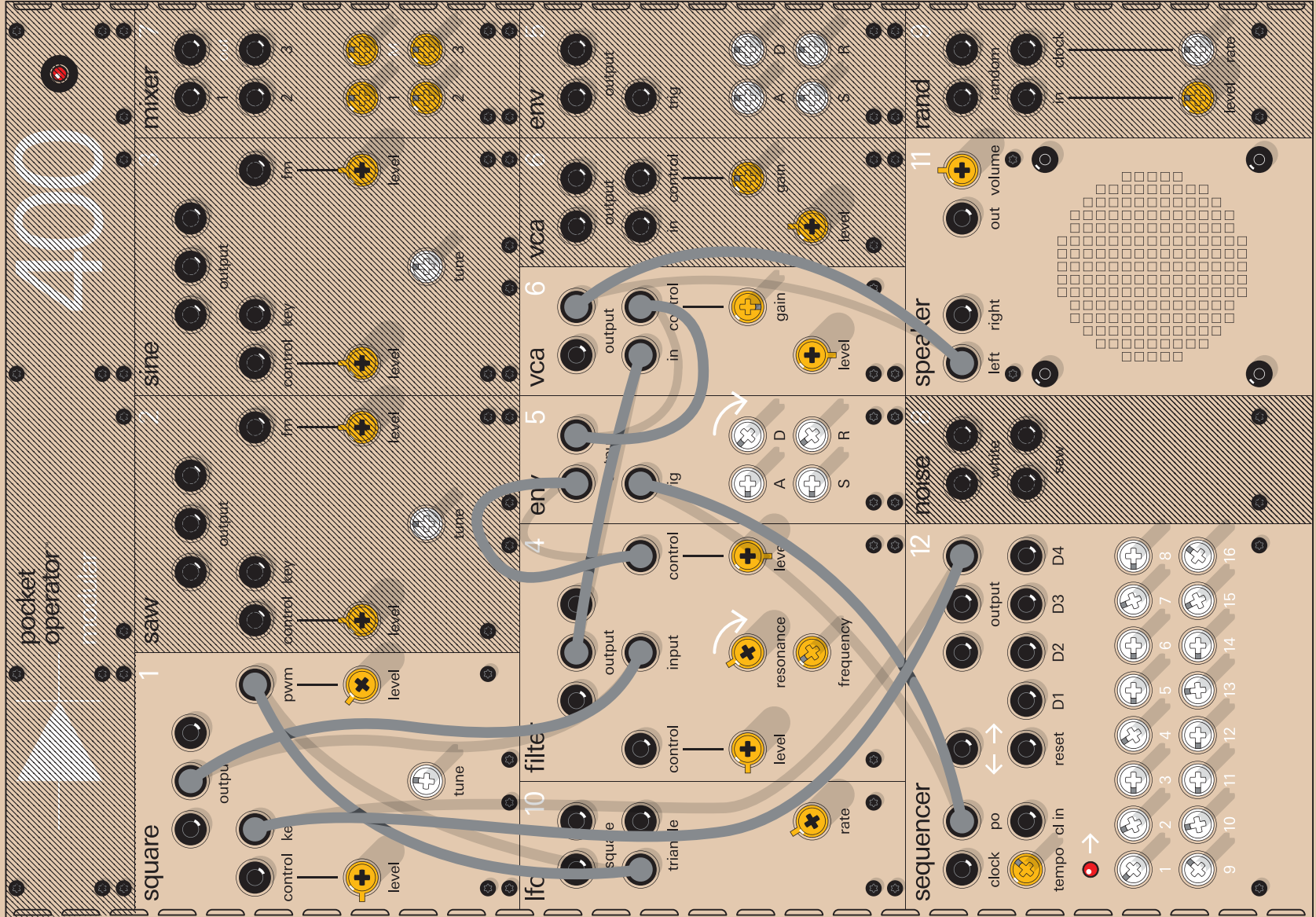

corpus sequentia

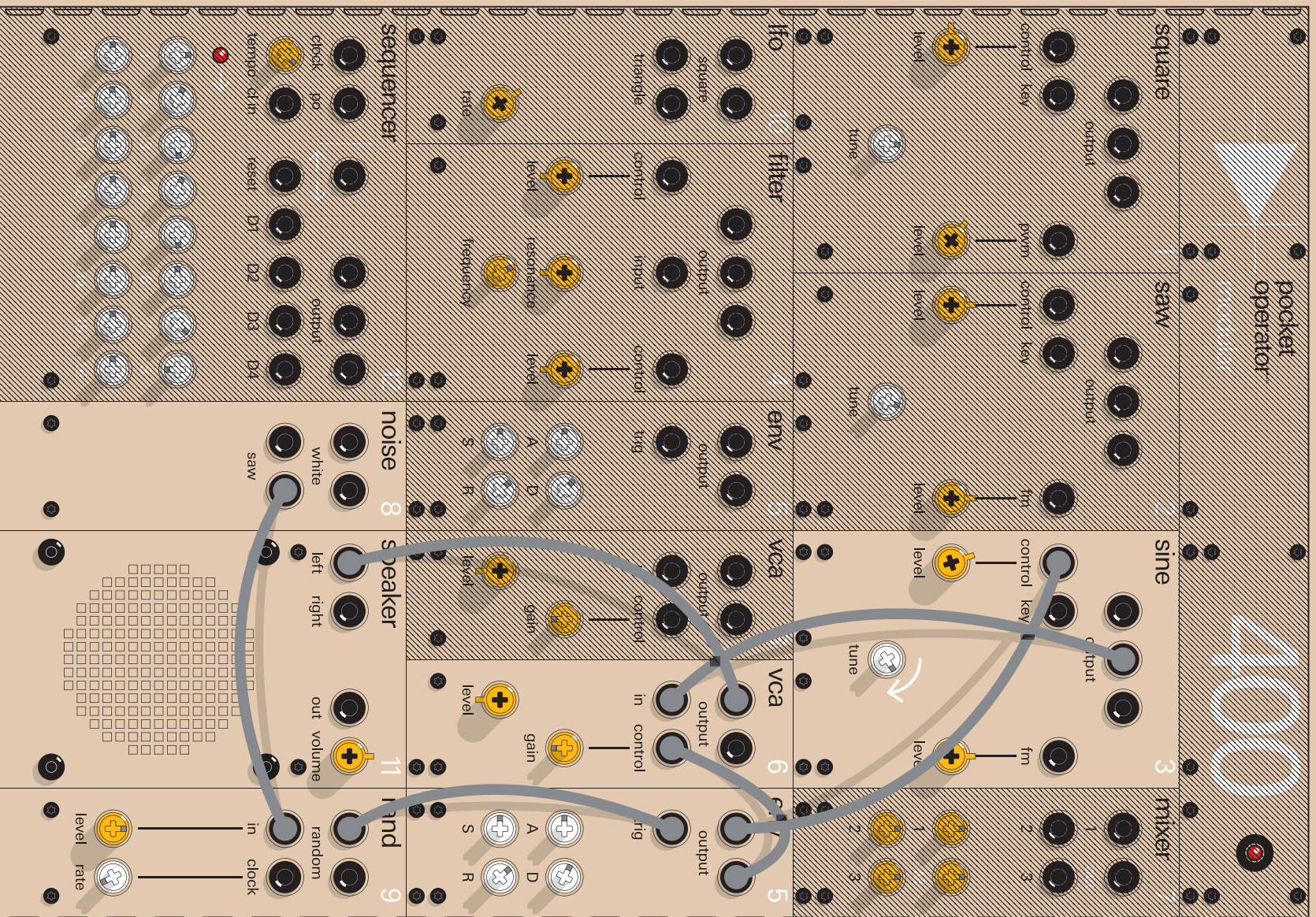

jazz drummer



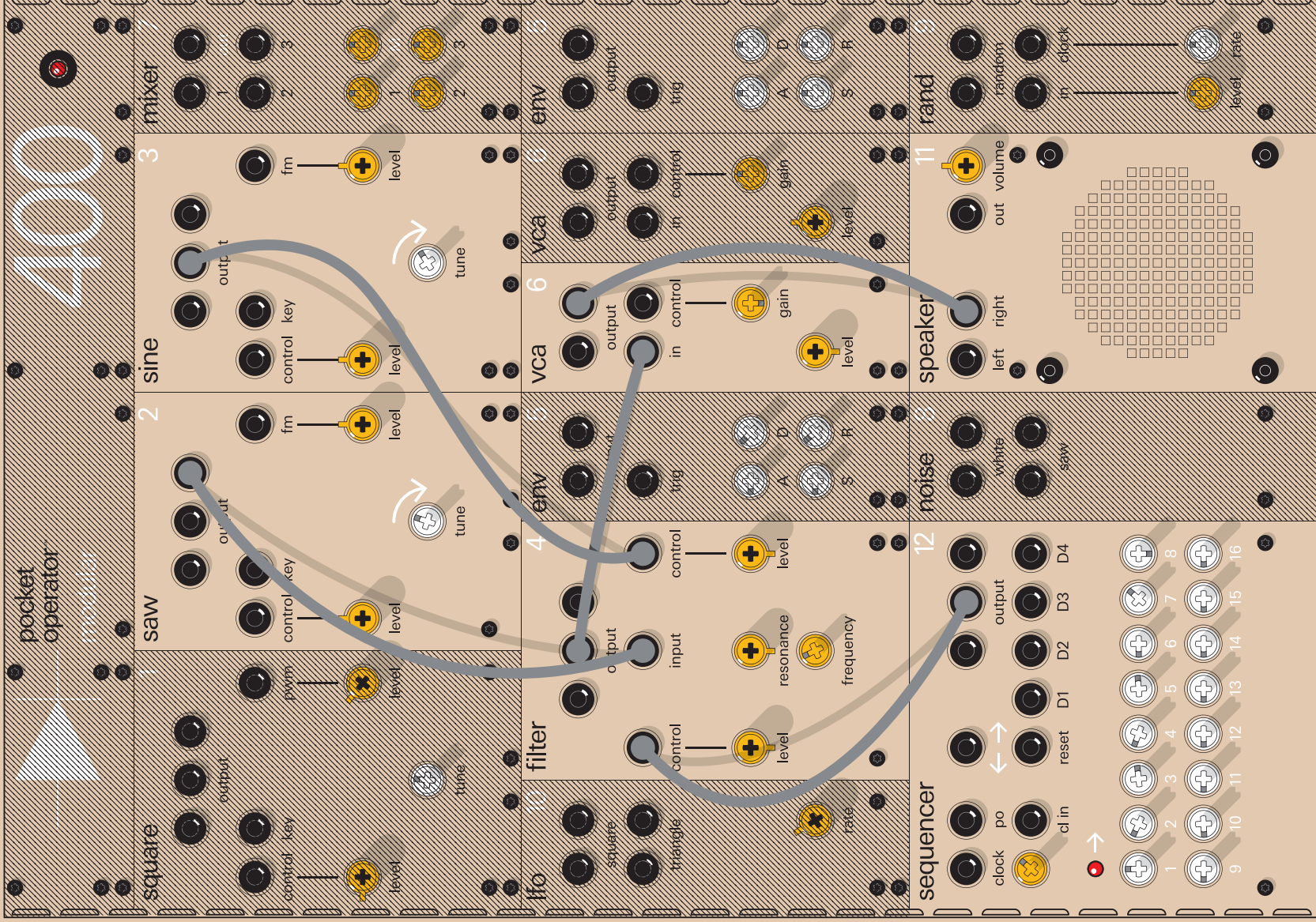

song from tibet

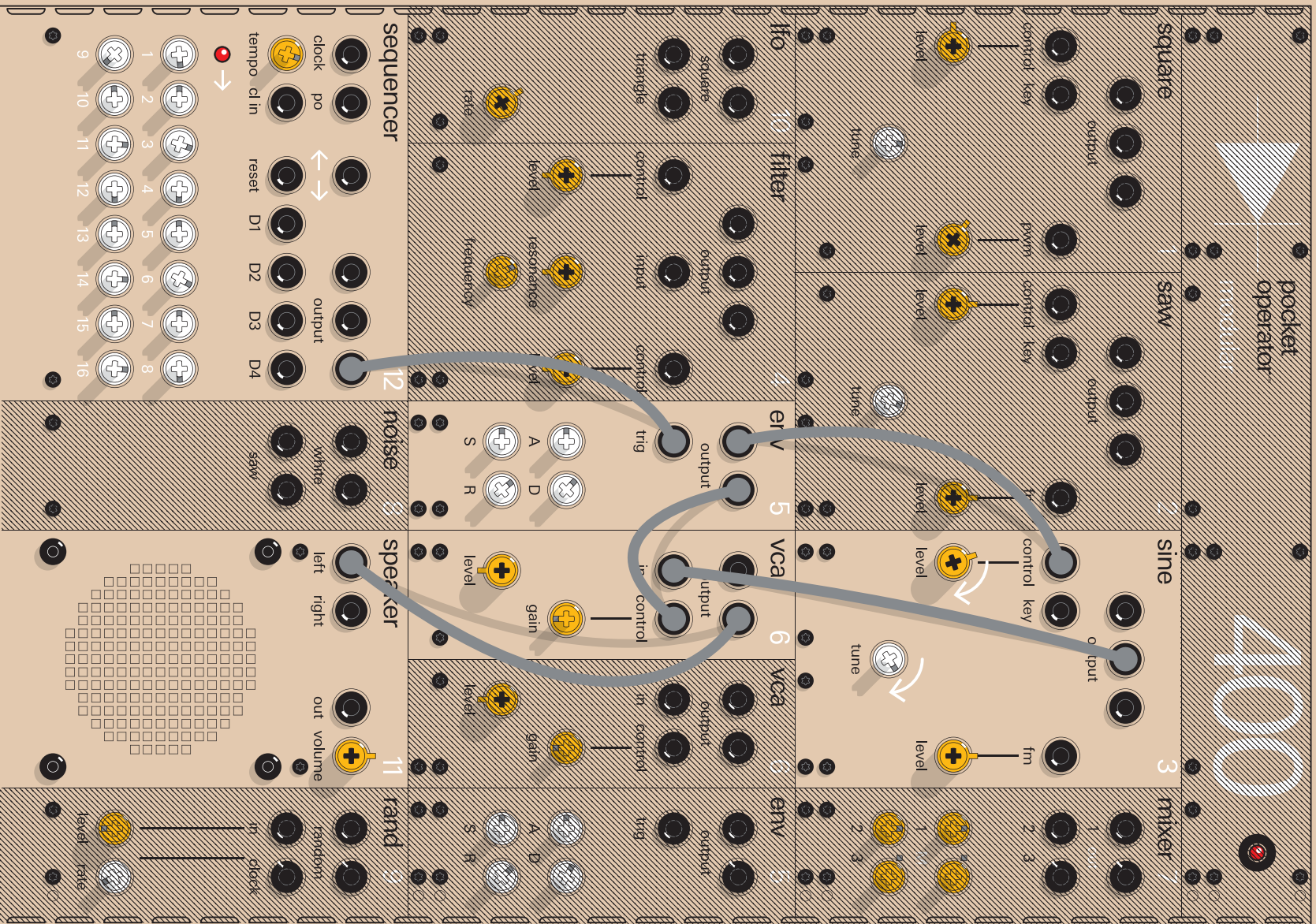

400



bird feeder



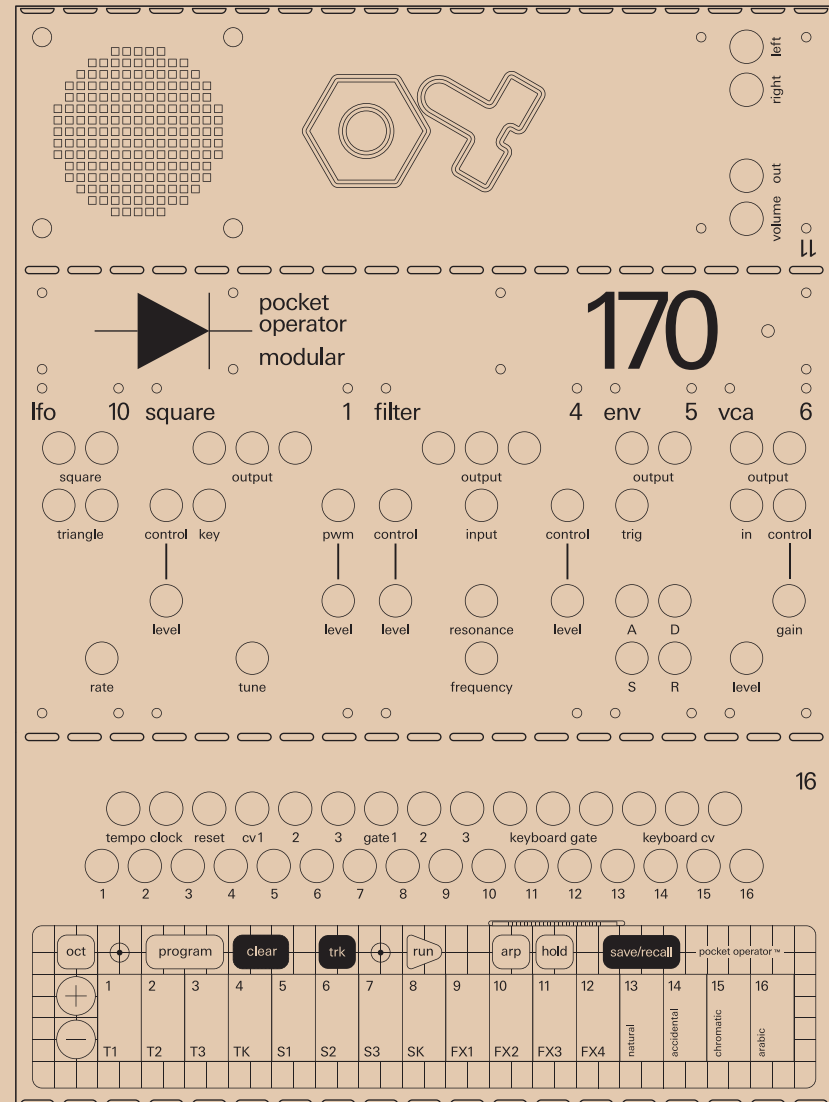
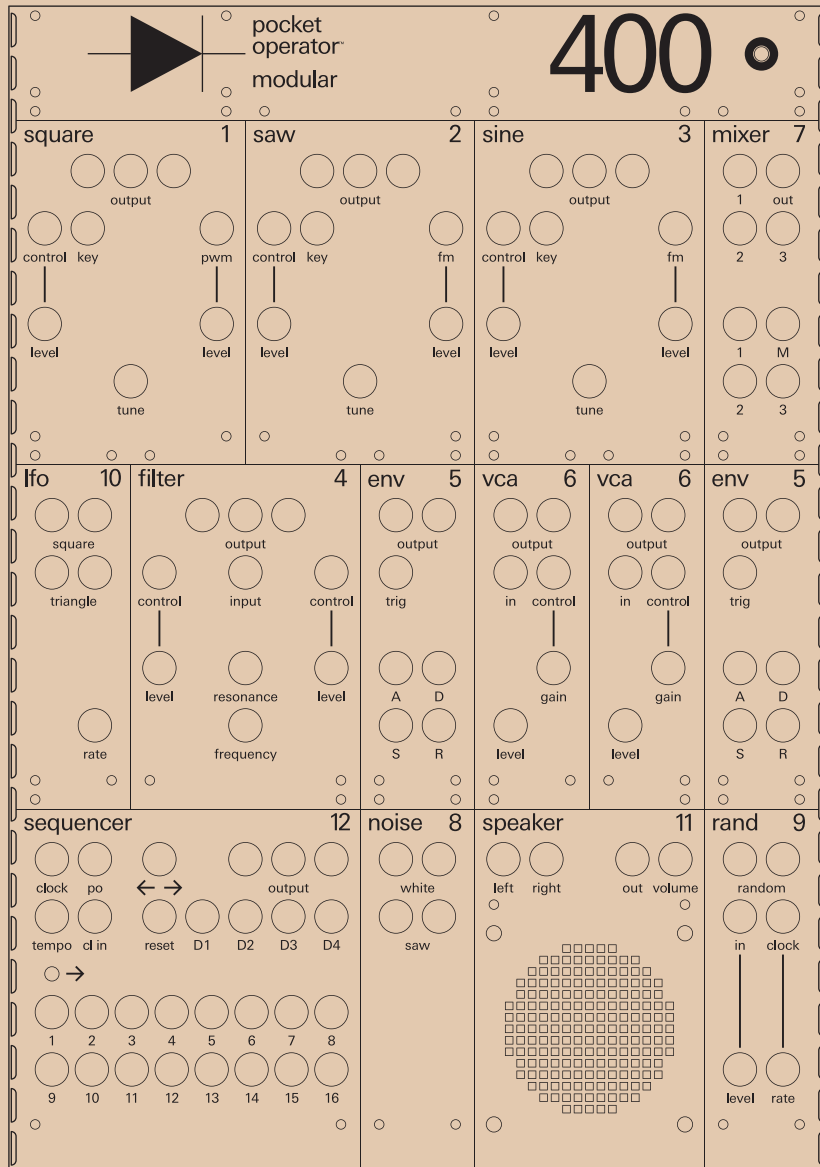

copy page and your own patches.

# add-on's

cable kit  
short

L 15 cm  
3.5 mm jack

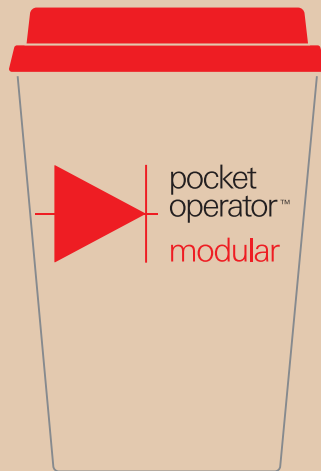

cable kit  
grande

L 30 cm  
3.5 mm jack

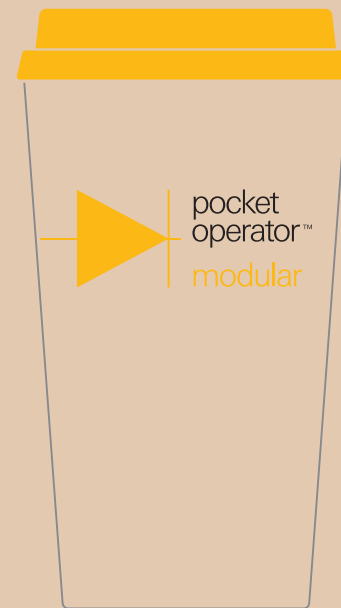

modular  
power  
adapter

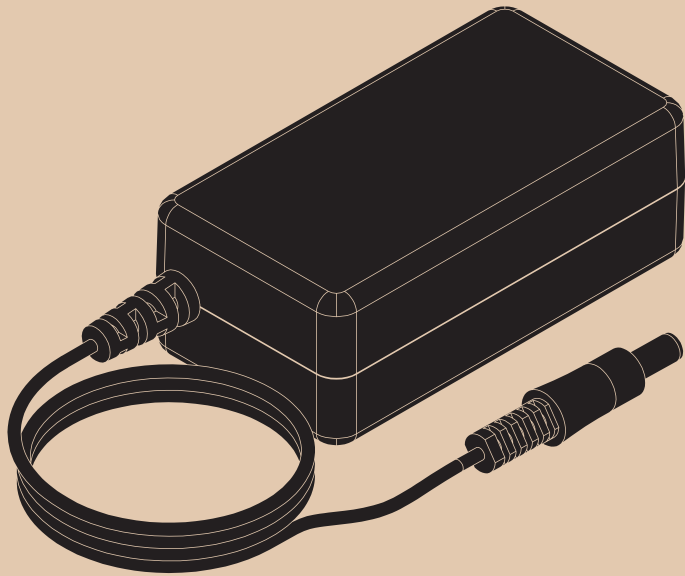

foldable hand  
promo

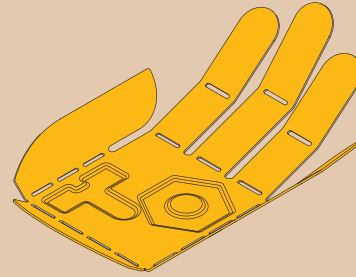

cable fork  
promo

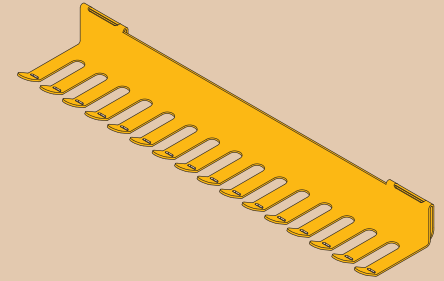

cable drawer  
promo

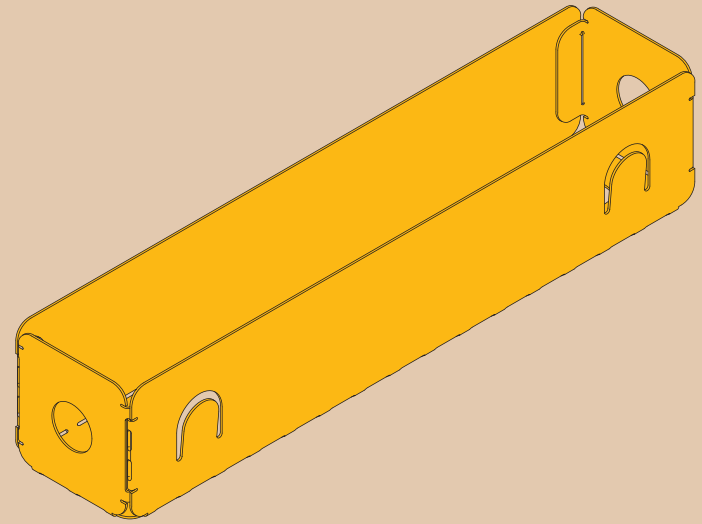

# measurements

400

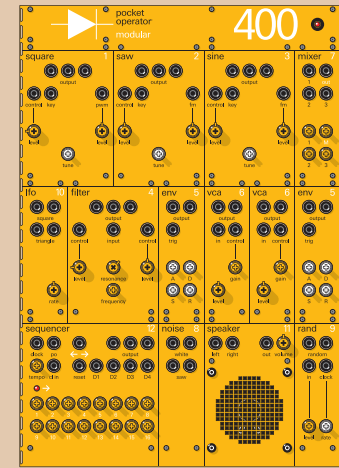
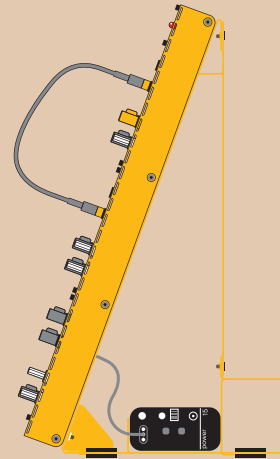
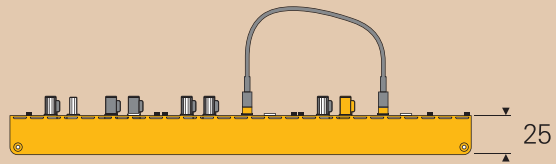

305

214

16

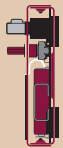

18

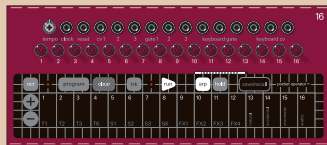

214

92.5

SCALE 1:5

all dimensions  
in mm

170

80.5

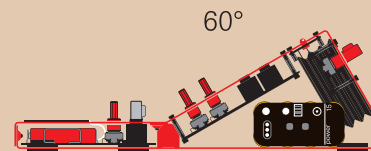

214

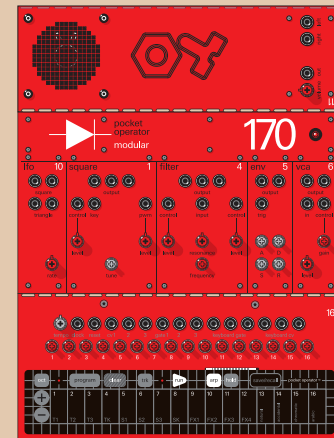

242

214

# system dimensions

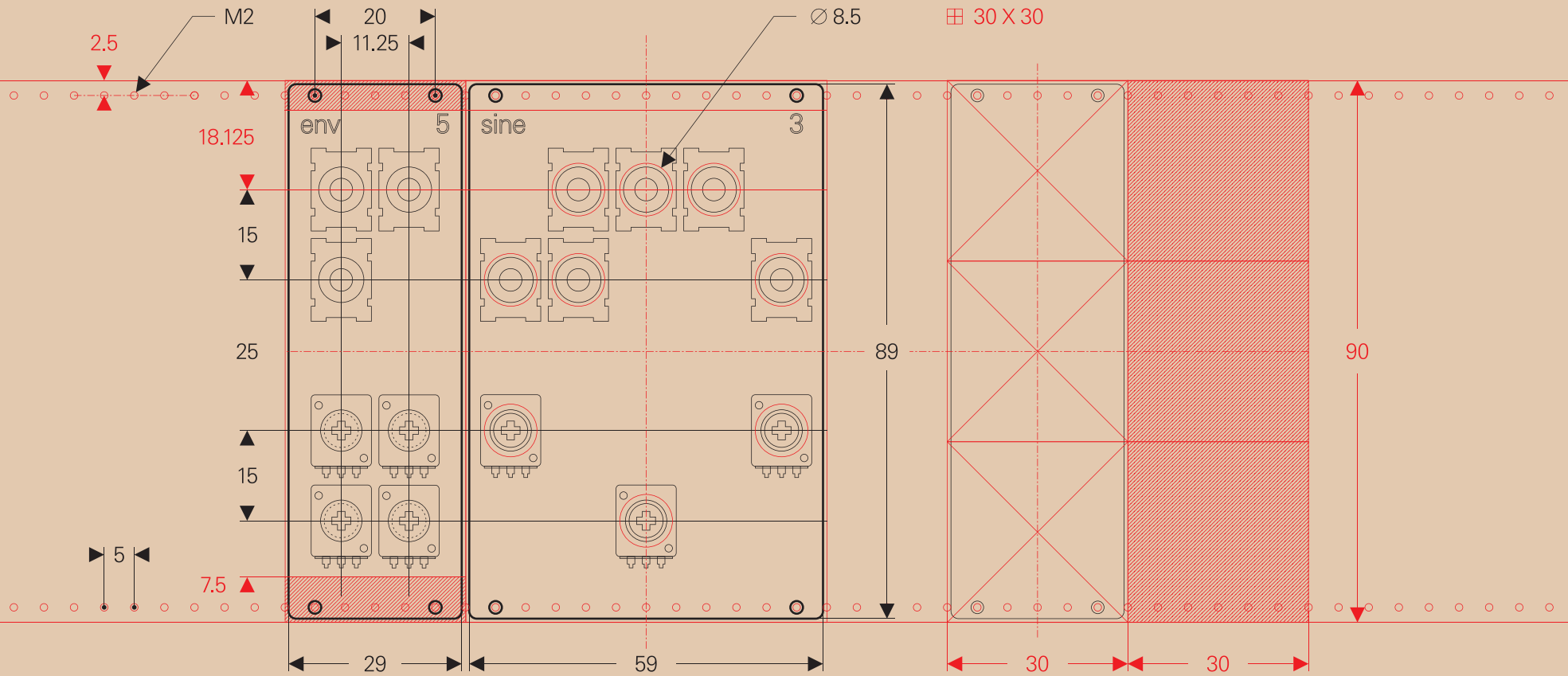

SCALE 1:1

all dimensions  
in mm

■ grid  
■ actual

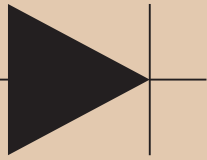

pocket operator™ goes modular!

create natural analog sound with this latest addition to the popular pocket operator™ series. explore a complete modular system with preconfigured

chassis for a smooth modular experience. upgrade to the open frame chassis when you are ready to expand your sonic universe beyond all limits.



an inner sonic journey designed and engineered by teenage engineering

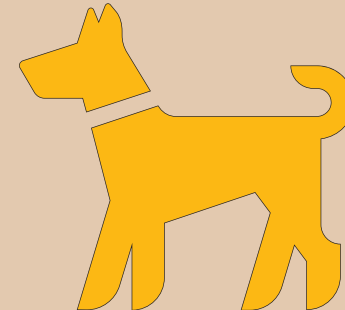
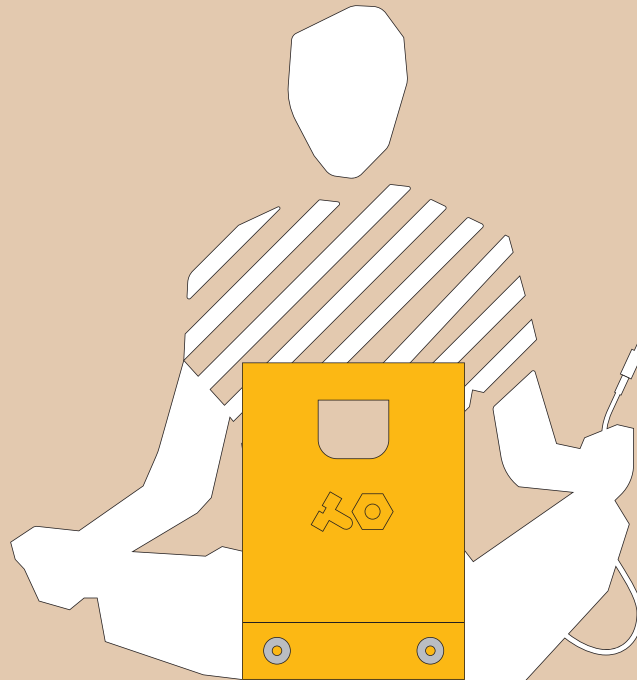

## 1-15

POCKET OPERATOR™ MODULAR SERIES 1

SQUARE OSCILLATOR, SAW OSCILLATOR, SINE OSCILLATOR, LOW PASS FILTER, NOISE, SAMPLE & HOLD, MIXER, VCA, LFO, SPEAKER & AMPLIFIER MODULE, SEQUENCER, ENVELOPE, POWER DISTRO & POWER PAC

for product updates, building tips and tutorials visit [teenage.engineering](http://teenage.engineering)

## 16

SHEET METAL CHASSIS MEMBRANE KEYBOARD

16 IS A MEMBRANE KEYBOARD WITH BUILT-IN PROGRAMMABLE SEQUENCER

☑ 1 MODULE

4 X AAA BATTERY POWERED

## 170

PRE-CONFIGURED 1-ROW CHASSIS WITH BUILT-IN KEYBOARD

170 IS A MONOPHONIC ANALOG SYNTHESIZER WITH BUILT-IN KEYBOARD AND PROGRAMMABLE SEQUENCER

☑ 7 MODULES

4 X AAA (KEYBOARD)  
8 X AA (12V POWER PACK)

## 400

PRE-CONFIGURED 3-ROW CHASSIS WITH CARRYING HANDLE

400 IS A COMPETENT MODULAR SYNTHESIZER WITH WARM NATURAL ANALOG SOUND. INCLUDES A 16-STEP SEQUENCER AND THREE OSCILLATORS

☑ 14 MODULES

8 X AA (12V POWER PACK)

770-00005